

**KESLA 2114Z, 2114ZT****Sisällysluettelo\Innehållsförteckning\Contents \Inhaltsverzeichnis**

Pääkokoontelo \ Sammansättning \ Final assembly \ Zusammensetzung .....	2
Käantölaite \ Vridanordning \ Slew mechanism \ Schwenkwerk .....	8
Tukijalkavarustus \ Stödbensutrustning \ Stabilizers \ Stützfußausrüstung .....	16
Nostopuomi \ Lyftbom \ Main lifting boom \ Hubarm .....	26
Siirtopuomisto \ Vipparm \ Outer boom \ Knickarm KESLA 2114Z .....	30
Siirtopuomisto \ Vipparm KESLA \ Outer boom \ Knickarm KESLA 2114ZT .....	33
Vetotanko varusteltuna \ Dragstång \ Inner link assy \ Mittleres Gelenk .....	40
Siirtopuomiston ketju \ Kedja \ Chain \ Kette kompl. \ .....	42
Siirtopuomiston ketju \ Kedja \ Chain \ Kette kompl. \ .....	44
Nostosylinteri varusteltuna \ Lyftcylinder utrustning \ Accessories for main lifting cylinder \ Ausrüstung für Hubzylinder .....	46
Nostosylinteri \ Lyftcylinder \ Main lifting cylinder \ Hubzylinder.....	48
Siirtosylinteri varusteltuna \ Vippcylinder utrustning \ Accessories for outer boom cylinder \ Ausrüstung für Knickarmzylinder.....	50
Siirtosylinteri \ Vippcylinder \ Outer boom cylinder \ Knickarmzylinder .....	52
Jatkeen sylinteri varusteltuna \ Utskjutscylinder utrustning \ Extension cylinder Accessories for \ Ausschubzylinder Ausrüstung für \ KESLA 2114Z.....	54
Jatkeen sylinteri \ Utskjutscylinder \ Extension cylinder \ Ausschubzylinder \ KESLA 2114Z .....	56
Jatkeen sylinteri \ Utskjutscylinder \ Extension cylinder \ Ausschubzylinder \ KESLA 2114ZT ....	58
Tukijalkojen levityssylinteri \ Spridningscylinder \ Spreading cylinder \ Ausshubzylinder für Stützfüsse .....	60
Tukijalan sylinteri kok.oikea+vasen\ Stödbenscylinder höger+vänster \ Stabilizer cylinder right+left\ Stützfußcylinder rechts+ links .....	62
Kiinnityssarja\ fastening kit \ Monteringssats \ Befestigungssatz .....	98

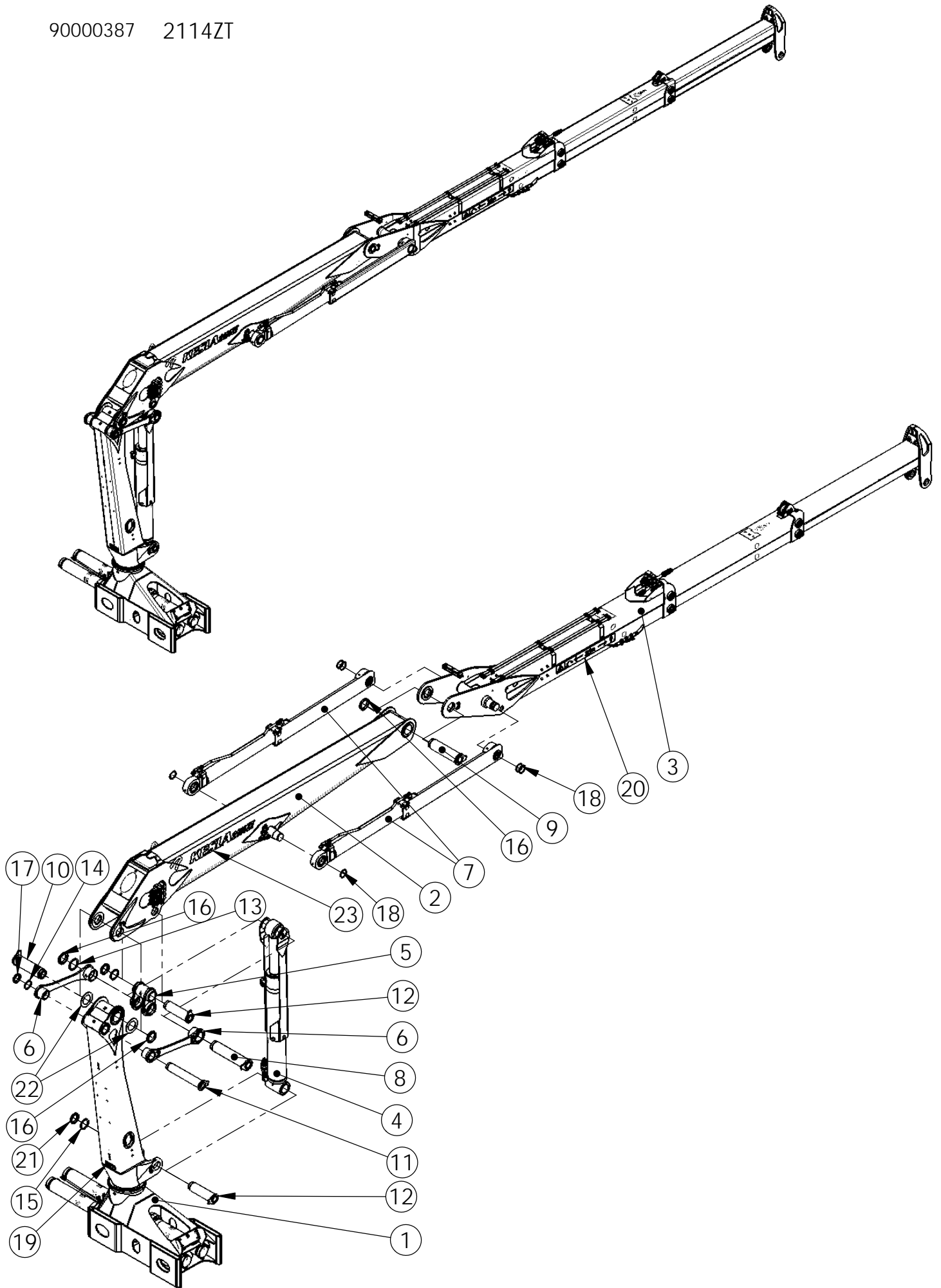

Item code	90000387	Revision	A
Title	CRANE	Date	07.12.2011
Specification	2114ZT 9.4M		

Pos	Item code	Title	Specification	Pc	Nto Weight
1	90025757	SLEW MECHANISM	RIGHT	1	701.35
2	90025044	LIFT BOOM	L=3620 VAR	1	333.16
3	90025077	OUTER BOOM	L=5995	1	450.38
4	90025098	CYLINDER	140 / 90 X 970 VAR	1	131.09
5	90024300	DRAW BAR	VAR	1	11.24
6	90024301	LINK	L= 595 HITS+KON	2	8.8
7	90025092	CYLINDER	100/70X880 VAR	2	80.18
8	90021059	AXLE	90-437 HITS	1	15.15
9	90021106	AXLE	90/M85X2 -360	1	12.51
10	90020768	AXLE	90/M85X2-337	1	11.72
11	90024305	AXLE	70/M65X2-433	1	9.75
12	90020764	AXLE	80/M75X2-300	2	8.07
13	90020815	WASHER	112/91-6	1	0.16
14	90016000	WASHER	85/71-6	1	0.08
15	90013697	WASHER	100/81-6	2	0.13
16	3020177	NUT	KM17 NYLOC M85X2	3	0.44
17	3020157	NUT	KM13 NYLOC M65X2.0	1	0.26
18	3060104	SNAP RING	AS 70X4 DIN 471	6	0
19	3281642	PLATE	120X45 CE	1	0.03
20	3281135	DECAL	VAARA-ALUE 25 M, 730X80	2	0.1
21	3020158	NUT	KM15 NYLOC M75X2	2	0.35
22	90020813	BEARING	142/90,5-5	2	0.05
23	3281534	DECAL	100 X 814 ( KESLA 2114ZT )	2	0.07

90000388  
2114Z

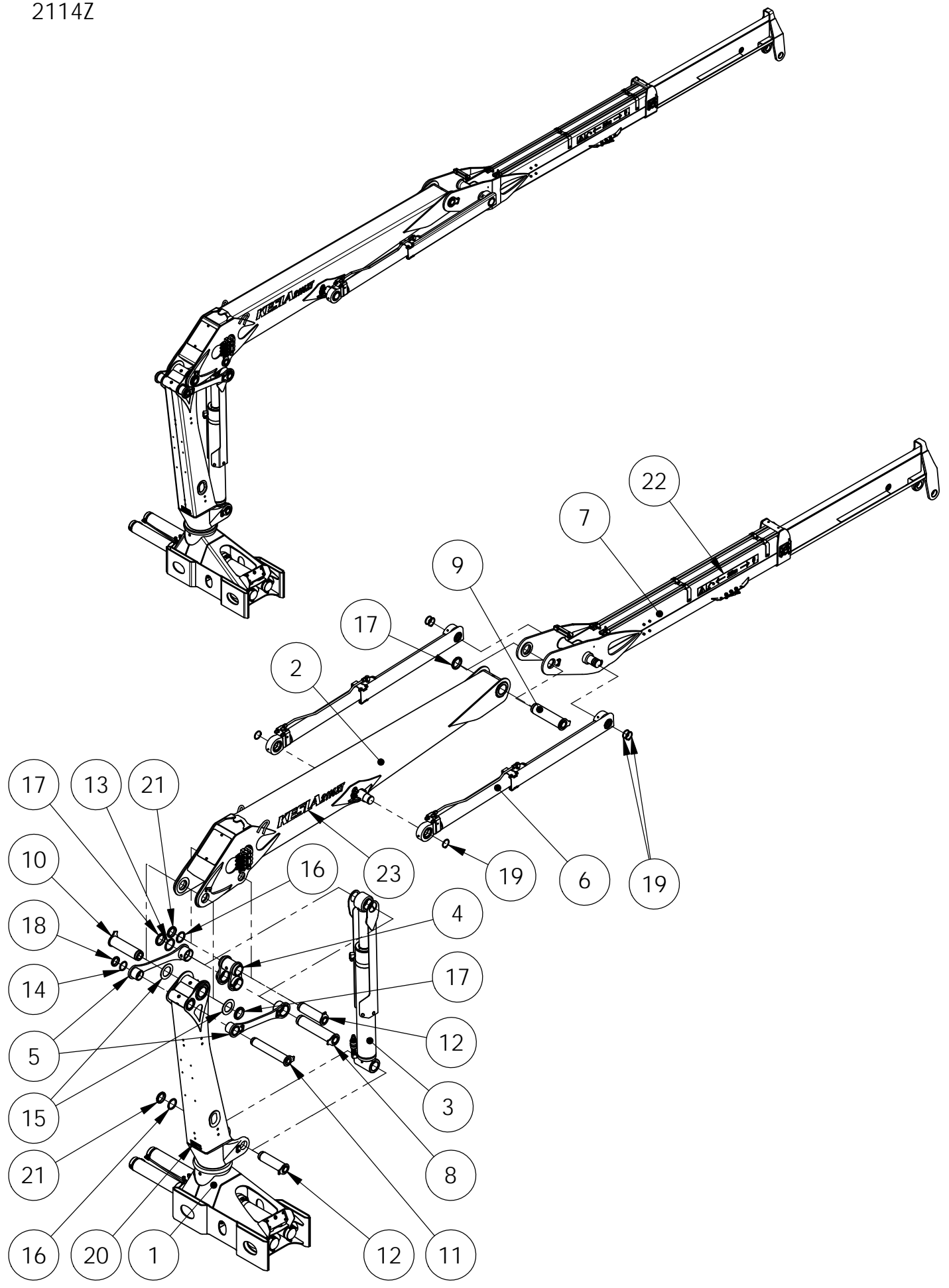

Item code	90000388	Revision	A
Title	CRANE	Date	05.12.2011
Specification	2114Z L=8078		

Pos	Item code	Title	Specification	Pc	Nto Weight
1	90025757	SLEW MECHANISM	RIGHT	1	701.35
2	90025044	LIFT BOOM	L=3620 VAR	1	333.16
3	90025098	CYLINDER	140 / 90 X 970 VAR	1	131.09
4	90024300	DRAW BAR	VAR	1	11.24
5	90024301	LINK	L= 595 HITS+KON	2	8.8
6	90025092	CYLINDER	100/70X880 VAR	2	80.18
7	90025143	OUTER BOOM	L=4700 1-JATK	1	367.37
8	90021059	AXLE	90-437 HITS	1	15.15
9	90021106	AXLE	90/M85X2 -360	1	12.51
10	90020768	AXLE	90/M85X2-337	1	11.72
11	90024305	AXLE	70/M65X2-433	1	9.75
12	90020764	AXLE	80/M75X2-300	2	8.07
13	90020815	WASHER	112/91-6	1	0.16
14	90016000	WASHER	85/71-6	1	0.08
15	90020813	BEARING	142/90,5-5	2	0.05
16	90013697	WASHER	100/81-6	2	0.13
17	3020177	NUT	KM17 NYLOC M85X2	3	0.44
18	3020157	NUT	KM13 NYLOC M65X2.0	1	0.26
19	3060104	SNAP RING	AS 70X4 DIN 471	6	0
20	3281642	PLATE	120X45 CE	1	0.03
21	3020158	NUT	KM15 NYLOC M75X2	2	0.35
22	3281135	DECAL	VAARA-ALUE 25 M, 730X80	2	0.1
23	3281534	DECAL	100 X 814 ( KESLA 2114ZT )	2	0.07

90000394  
2114ZT

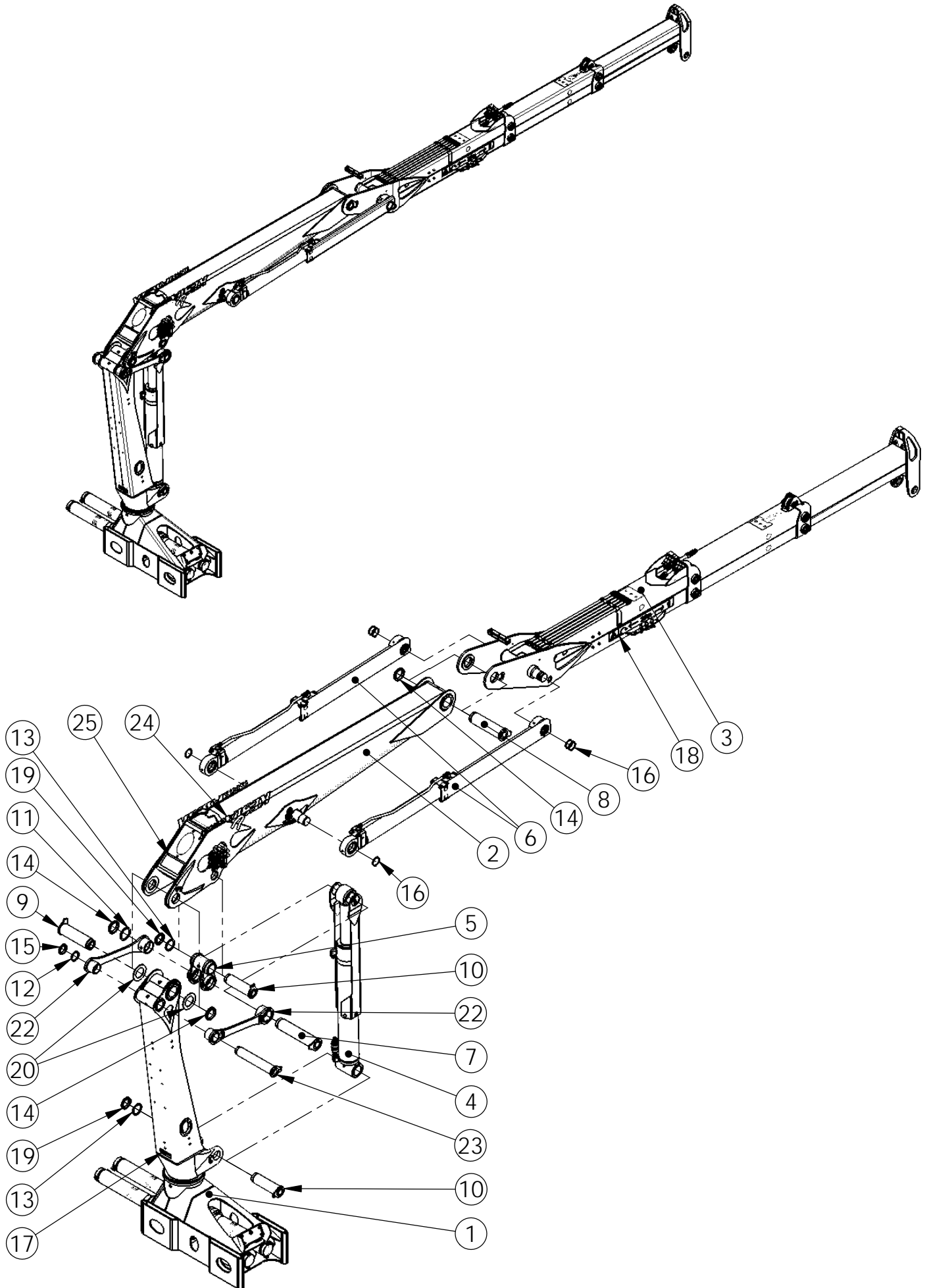

Item code	90000394	Revision	-
Title	CRANE	Date	16.08.2012
Specification	2114ZT L=7695		

Pos	Item code	Title	Specification	Pc	Nto Weight
1	90025500	SLEW MECHANISM	31 KNM	1	697.83
2	90025205	LIFT BOOM	3100 RIGHT VAR	1	304.67
3	90025214	OUTER BOOM	L=4835 / 6-HOSES	1	400.35
4	90025098	CYLINDER	140 / 90 X 970 VAR	1	131.09
5	90024300	DRAW BAR	VAR	1	11.24
6	90025092	CYLINDER	100/70X880 VAR	2	80.18
7	90021059	AXLE	90-437 HITS	1	15.15
8	90021106	AXLE	90/M85X2 -360	1	12.51
9	90020768	AXLE	90/M85X2-337	1	11.72
10	90020764	AXLE	80/M75X2-300	2	8.07
11	90020815	WASHER	112/91-6	1	0.16
12	90016000	WASHER	85/71-6	1	0.08
13	90013697	WASHER	100/81-6	2	0.13
14	3020177	NUT	KM17 NYLOC M85X2	3	0.44
15	3020157	NUT	KM13 NYLOC M65X2.0	1	0.26
16	3060104	SNAP RING	AS 70X4 DIN 471	6	0
17	3281642	PLATE	120X45 CE	1	0
18	3281135	DECAL	VAARA-ALUE 25 M, 730X80	2	0.1
19	3020158	NUT	KM15 NYLOC M75X2	2	0.35
20	90020813	BEARING	142/90,5-5	2	0.05
21	90025314	SUPPORT	RIGHT ASSEMBLY	1	8.45
22	90024301	LINK	L= 595 HITS+KON	2	8.8
23	90024305	AXLE	70/M65X2-433	1	9.75
24	3281534	DECAL	100 X 814 ( KESLA 2114ZT )	2	0.07
25	3281549	PLATE	100X200 KESLA 2114ZT/2117ZT 7.7	1	0.16

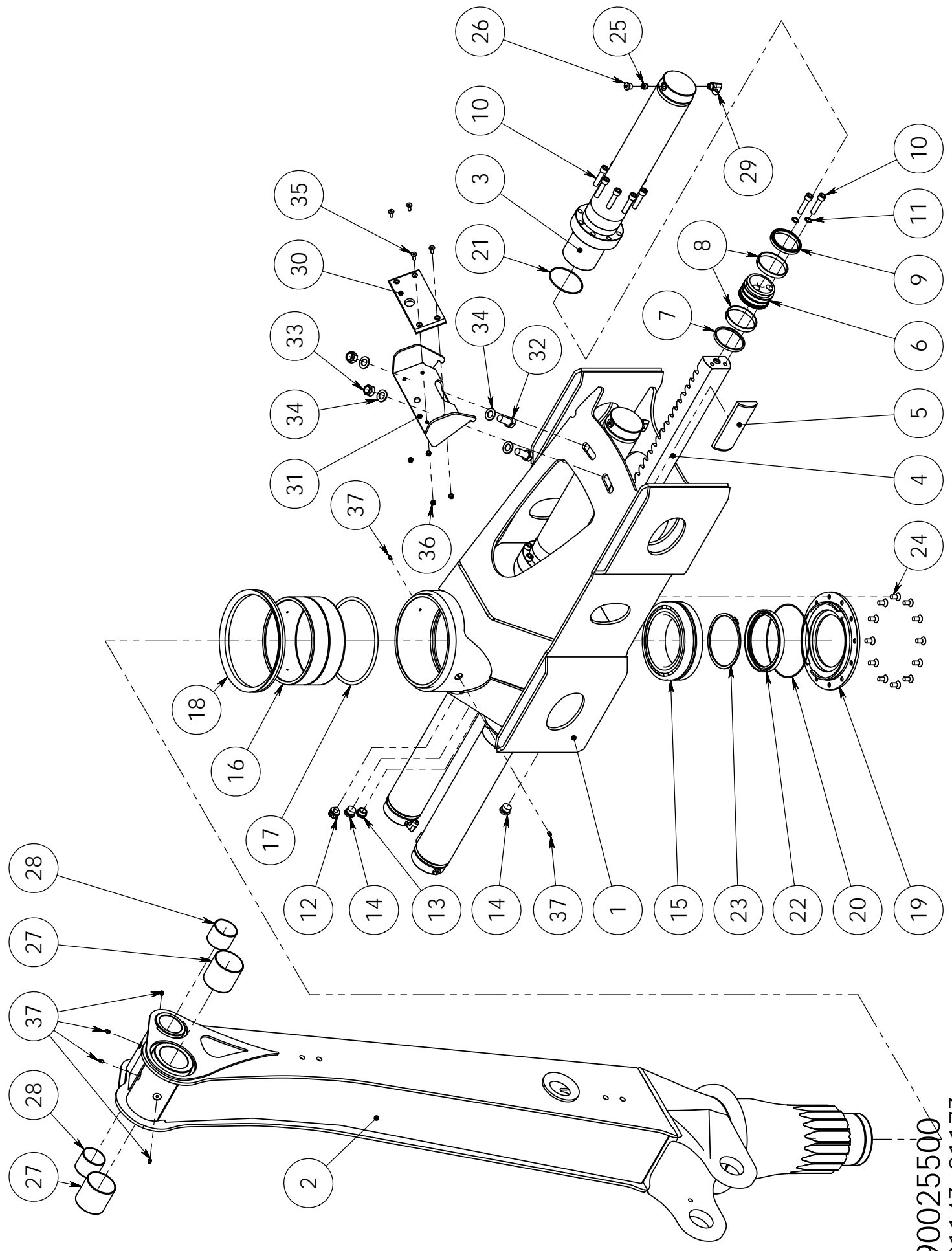

90025500  
 2114Z, 2117Z  
 SLEW MECHANISM





## SPARE PART LIST

Item code	90025500	Revision	D
Title	SLEW MECHANISM	Date	11.07.2012
Specification	31 KNM		

Pos	Item code	Title	Specification	Pc	Nto Weight
1	90025515	FRAME	HITS/KON VAIHE 2	1	237.01
2	90025539	PILLAR	HITSAUS + KONEISTUS	1	300.17
3	90025484	CYLINDER	D=100 L=757	4	18.75
4	90025498	RACK BAR	95-856	2	24.23
5	90025511	BUSHING	22X70-193	2	0.3
6	90025499	PISTON	D=100	4	2.77
7	3110530	WIPER SEAL	PPW 100/91.4X5.3	4	0.06
8	3110072	PISTON GUIDE	E/PWR 100/94X13	8	0.09
9	3110529	PISTON SEAL	B7 100/85X12	4	0.18
10	3010601	ALLEN SCREW	M14X60 12.9 DIN 912	40	0
11	3030080	WASHER	M14 KUPARIALUSLEVY	8	0
12	3091042	BREATHER		1	0.11
13	3090294	OIL LEVEL INDICATOR		1	0.01
14	3090209	PLUG		2	0.08
15	3100247	ROLLER BEARING	23032 CC/W33	1	9.05
16	90014957	BUSHING	270/250-120	1	1.11
17	3110987	O-RING	260X10 NBR70	1	0.5
18	3110930	SEAL	VA-300	1	1.63
19	90020924	FLANGE		1	4.61
20	3110771	O-RING	219.5X3.0 70 SHORE	1	0.04
21	3110659	O-RING	106X3 70 SHORE	4	0.02
22	3110878	SHAFT SEAL	160/190X15 AS	1	0.53
23	3060050	SNAP RING	160X4 DIN 471	1	0
24	3010315	ALLEN SCREW	M12X25 10.9 ZN DIN 7991	12	0
25	3120363	CHECK VALVE		4	0.02
26	3090210	PLUG		4	0.03
27	3100382	BUSHING	WB 802 9090	2	0.51
28	3100185	BUSHING	WB 802 7060	2	0.27
29	3090630	CONNECTOR (ANGLE)	6310-06-08	4	0.1
30	90018948	GUIDE PAD	100 X 220	1	0.22
31	90025599	SUPPORT	KULJETUSTUKI HITS	1	4.26
32	3010326	HEW SCREW	M20X45 8.8 ZN DIN 933	2	0
33	3020009	NUT	M20 ZN DIN 985	2	0.07
34	3030055	WASHER	M20 ZN DIN 125	4	0.02
35	3010300	ALLEN SCREW	M8X25 10.9 ZN DIN 7991	4	0
36	3020001	NUT	M8 ZN DIN 985	4	0.01



## SPARE PART LIST

Item code	90025500	Revision	D
Title	SLEW MECHANISM	Date	11.07.2012
Specification	31 KNM		

Pos	Item code	Title	Specification	Pc	Nto Weight
37	3050003	GREASE NIPPLE	M8X1,25 DIN 71412	6	0
50	3111098	SEAL KIT	D=100	1	0



90025757  
2114Z, 2117Z  
SLEW MECHANISM RIGHT

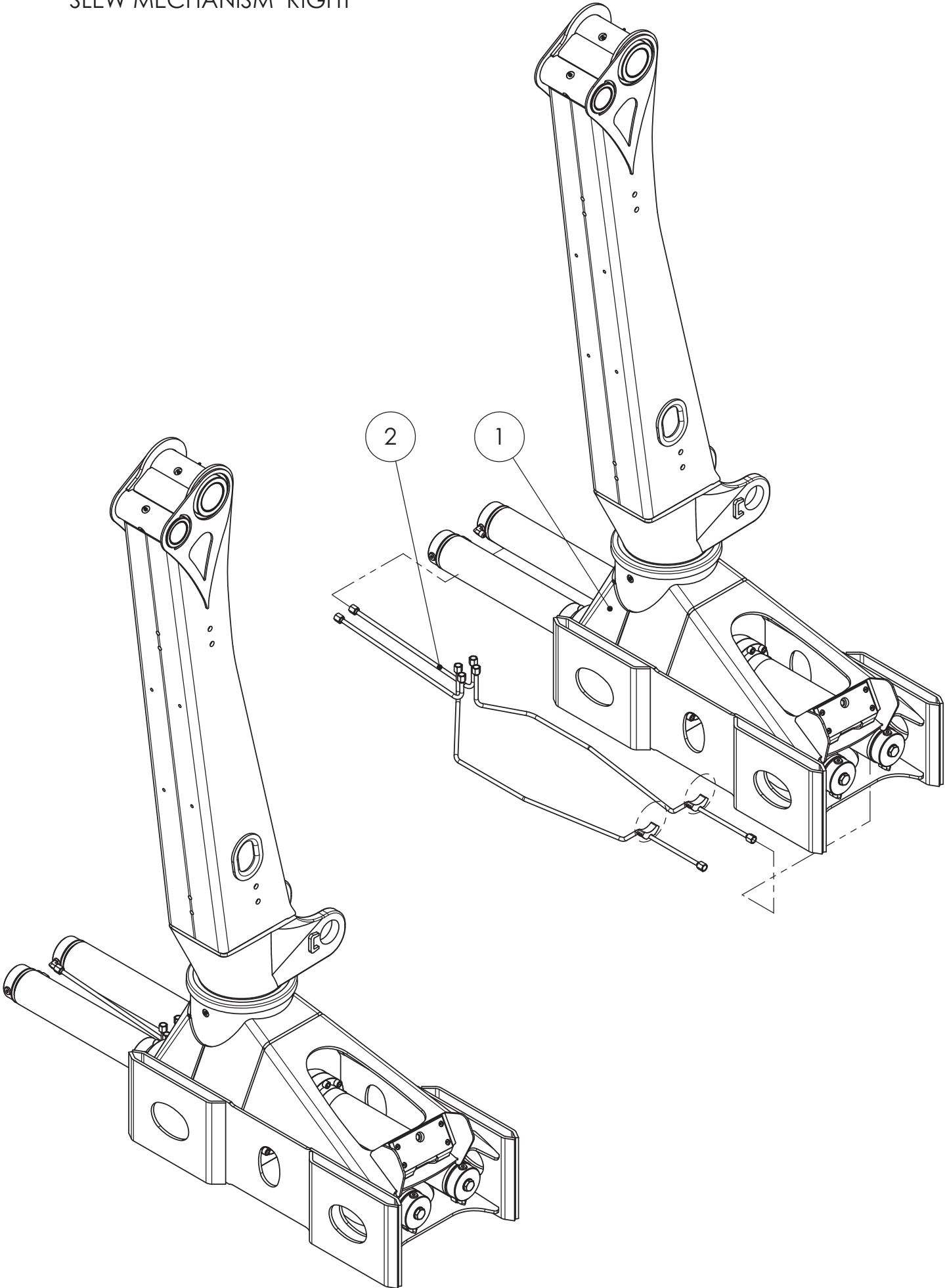

Item code	90025757	Revision	-
Title	SLEW MECHANNISM	Date	24.09.2012
Specification	RIGHT		

Pos	Item code	Title	Specification	Pc	Nfo Weight
1	90025500	SLEW MECHANNISM	31 KNM	1	705.96
2	90025628	HYDRAULIC PIPE	SLEW RIGHT	1	2.26

90025758  
2114Z, 2117Z  
SLEW MECHANISM LEFT

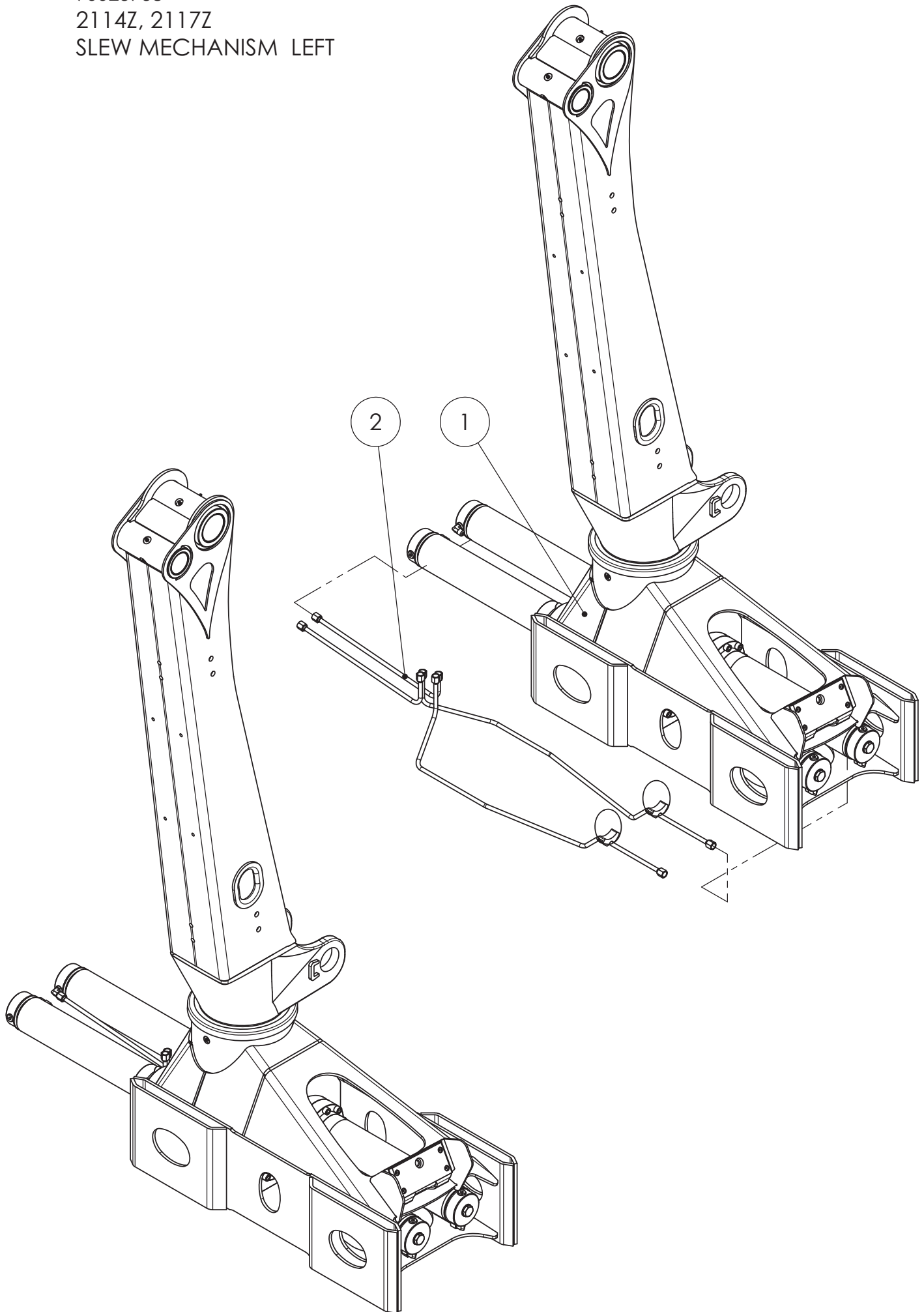

Item code	90025758	Revision	-
Title	SLEW MECHANNISM	Date	24.09.2012
Specification	LEFT		

Pos	Item code	Title	Specification	Pc	Nfo Weight
1	90025500	SLEW MECHANNISM	31 KNM	1	705.96
2	90025665	HYDRAULIC PIPE	SLEW LEFT	1	2.26

90025343  
2114Z,2117Z STABILIZER L=3840

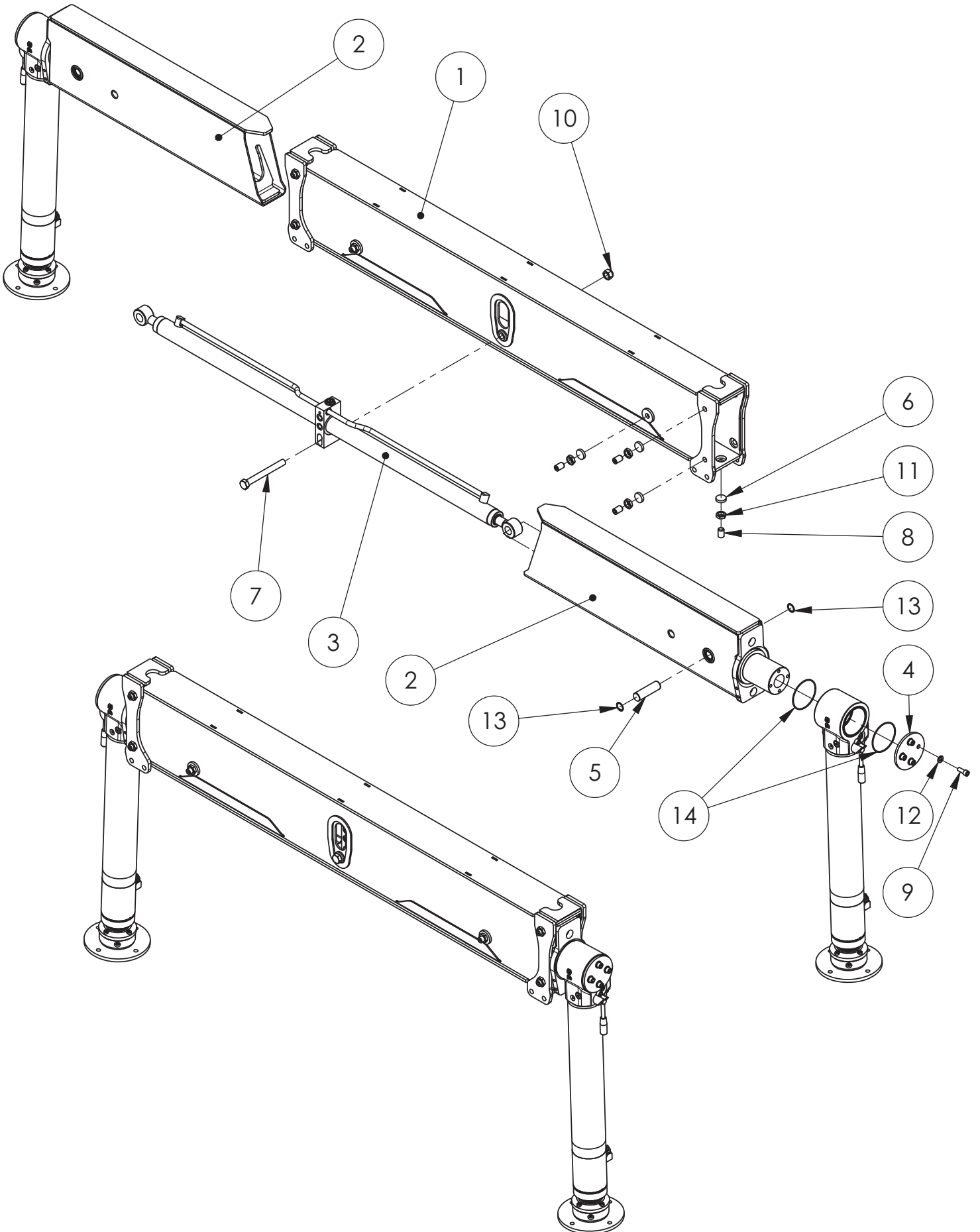



Item code	90025343	Revision	-
Title	STABILIZER	Date	10.02.2012
Specification	L=3840		

Pos	Item code	Title	Specification	Pc	Nto Weight
1	90025318	BEAM	TUKIJALKAPALKKI HITS	1	114.54
2	90025339	CONTROL ARM	HITS	2	45.05
3	28864001	SPREADING CYLINDER	50/30X2X650	1	27.75
4	90011250	FLANGE	135 - 8	2	0.86
5	90013050	AXLE	30-102	2	0.57
6	90020807	GLIDE PAD	35 - 8	8	0.01
7	3010224	HEW SCREW	M20X180 8.8 ZN DIN 931	1	0
8	3010312	ALLEN SCREW	M20X30 10.9 ZN DIN 913	8	0
9	3010246	ALLEN SCREW	M12X30 8.8 ZN DIN 912	8	0
10	3020009	NUT	M20 ZN DIN 985	1	0.07
11	3020014	NUT	M20 ZN DIN 936	8	0
12	3030047	WASHER	M12/13 ZN DIN 126	8	0.01
13	3060019	SNAP RING	30 DIN 472	4	0
14	3110259	O-RING	104.5X3 90 SHORE	4	0.02

90025363

2114Z,2117Z TILT STANDARD

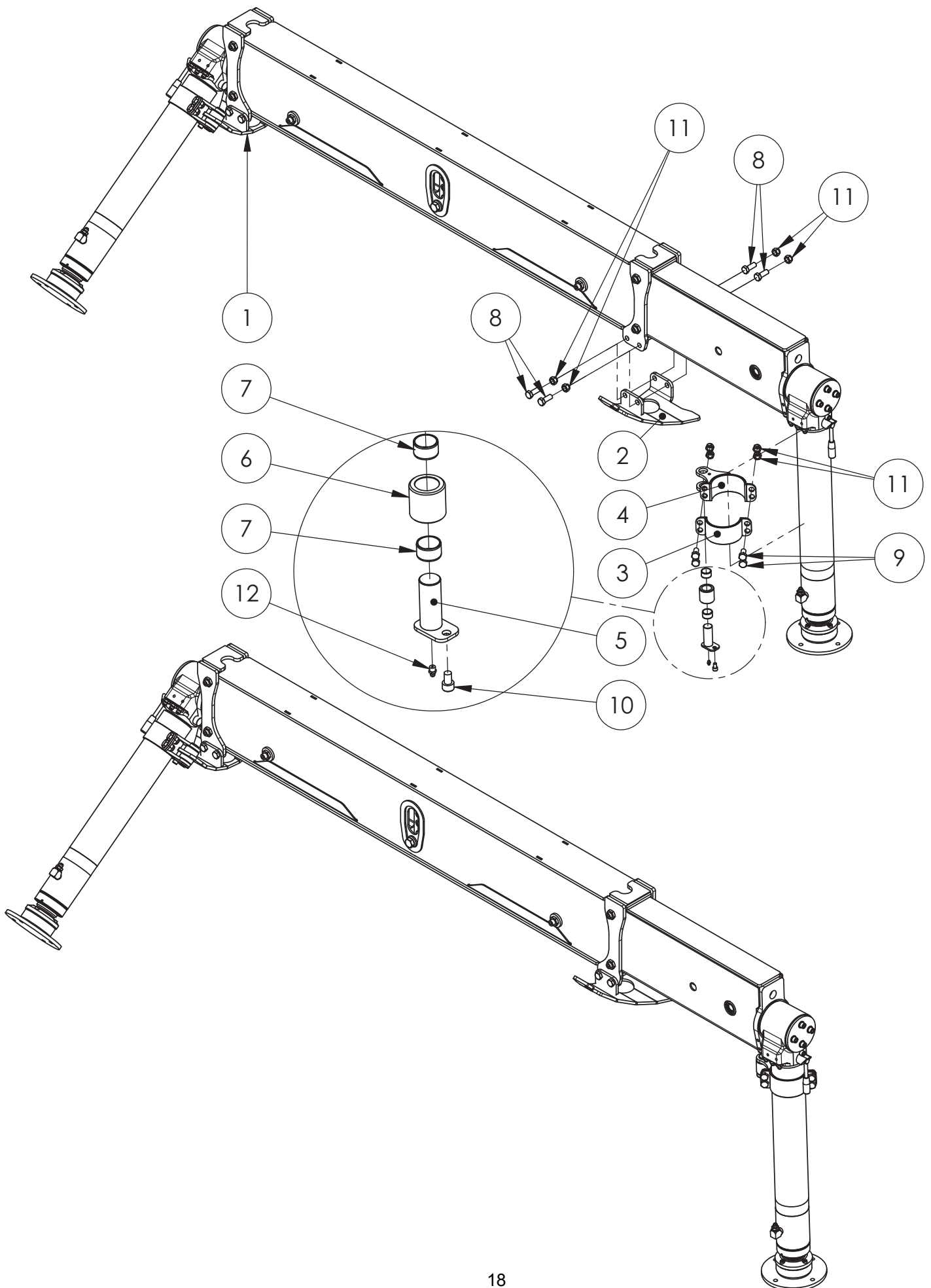

Item code	90025363	Revision	-
Title	STABILIZER	Date	16.02.2012
Specification	TILT STANDARD		

Pos	Item code	Title	Specification	Pc	Nto Weight
1	90024286	CABLE	RIGHT	1	3.82
2	90024288	CABLE	LEFT	1	3.82
3	90025351	FASTENER		2	0.76
4	90025366	BAND	RULLAPANTA HITS+KON	2	1.34
5	90015129	AXLE	30-84 HITS	2	0.48
6	90012841	SLEEVE	50/34-50	2	0.41
7	3100124	BUSHING	PM 3020 DX	4	0.03
8	3010024	HEW SCREW	M16X40 8.8 ZN DIN 933	8	0
9	3010025	HEW SCREW	M16X30 8.8 ZN DIN 933	8	0
10	3010898	ALLEN SCREW	M10X16 8.8 ZN DIN 912	2	0
11	3020010	NUT	M16 ZN DIN 985	16	0.03
12	3050003	GREASE NIPPLE	M8X1,25 DIN 71412	2	0

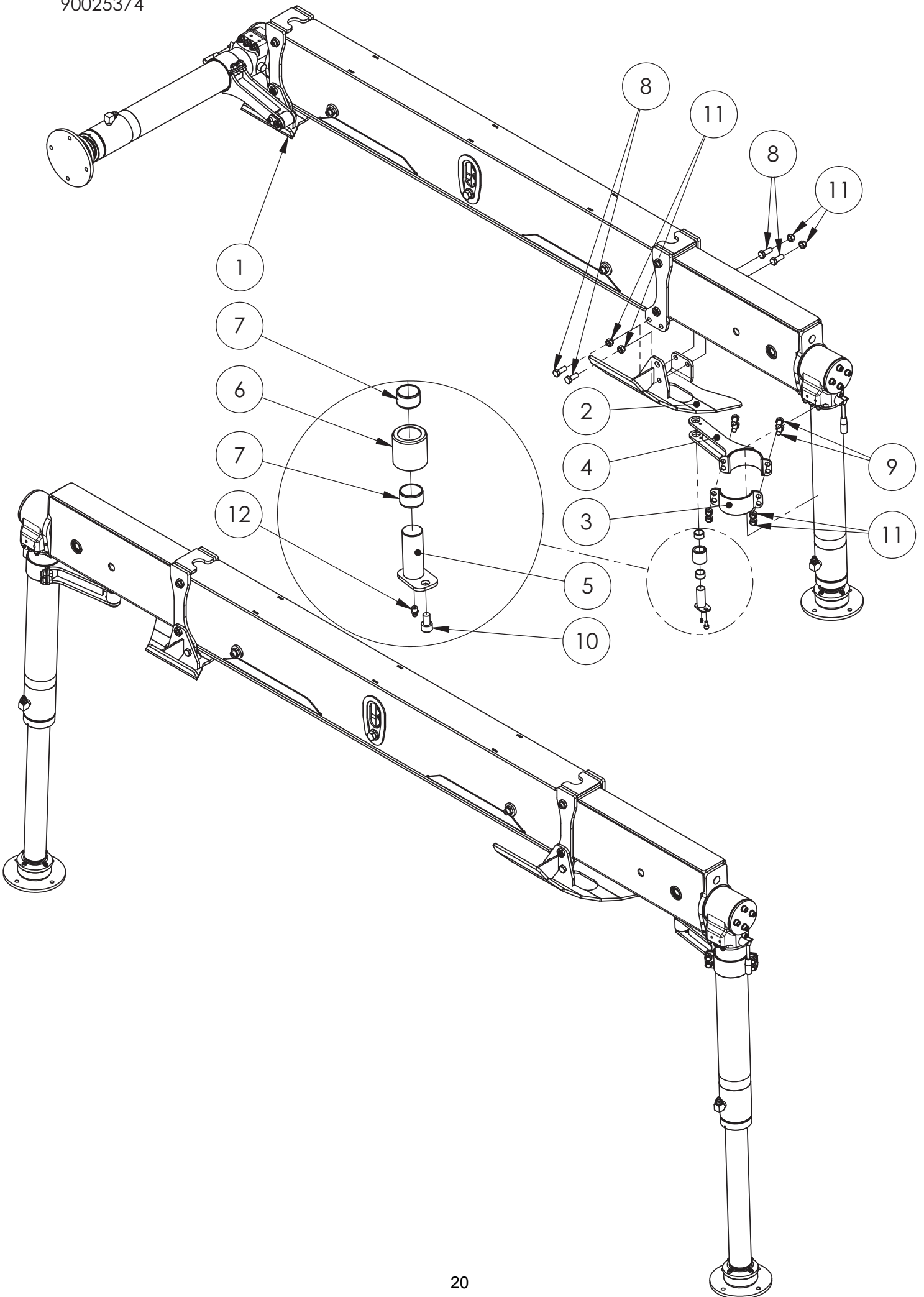

Item code	90025374	Revision	-
Title	STABILIZER	Date	21.02.2012
Specification	TILT 90 DEG		

Pos	Item code	Title	Specification	Pc	Nto Weight
1	90025377	CABLE	OIKEA PITKÄ	1	8.57
2	90025378	CABLE	VASEN PITKÄ	1	8.57
3	90025351	FASTENER		2	0.76
4	90025375	BAND	RULLAPANTA PITKÄ D=115	2	3.38
5	90015129	AXLE	30-84 HITS	2	0.48
6	90012841	SLEEVE	50/34-50	2	0.41
7	3100124	BUSHING	PM 3020 DX	4	0.03
8	3010024	HEW SCREW	M16X40 8.8 ZN DIN 933	8	0
9	3010025	HEW SCREW	M16X30 8.8 ZN DIN 933	8	0
10	3010898	ALLEN SCREW	M10X16 8.8 ZN DIN 912	2	0
11	3020010	NUT	M16 ZN DIN 985	16	0.03
12	3050003	GREASE NIPPLE	M8X1,25 DIN 71412	2	0

90025356  
2114Z,2117Z TILT 180 DEG

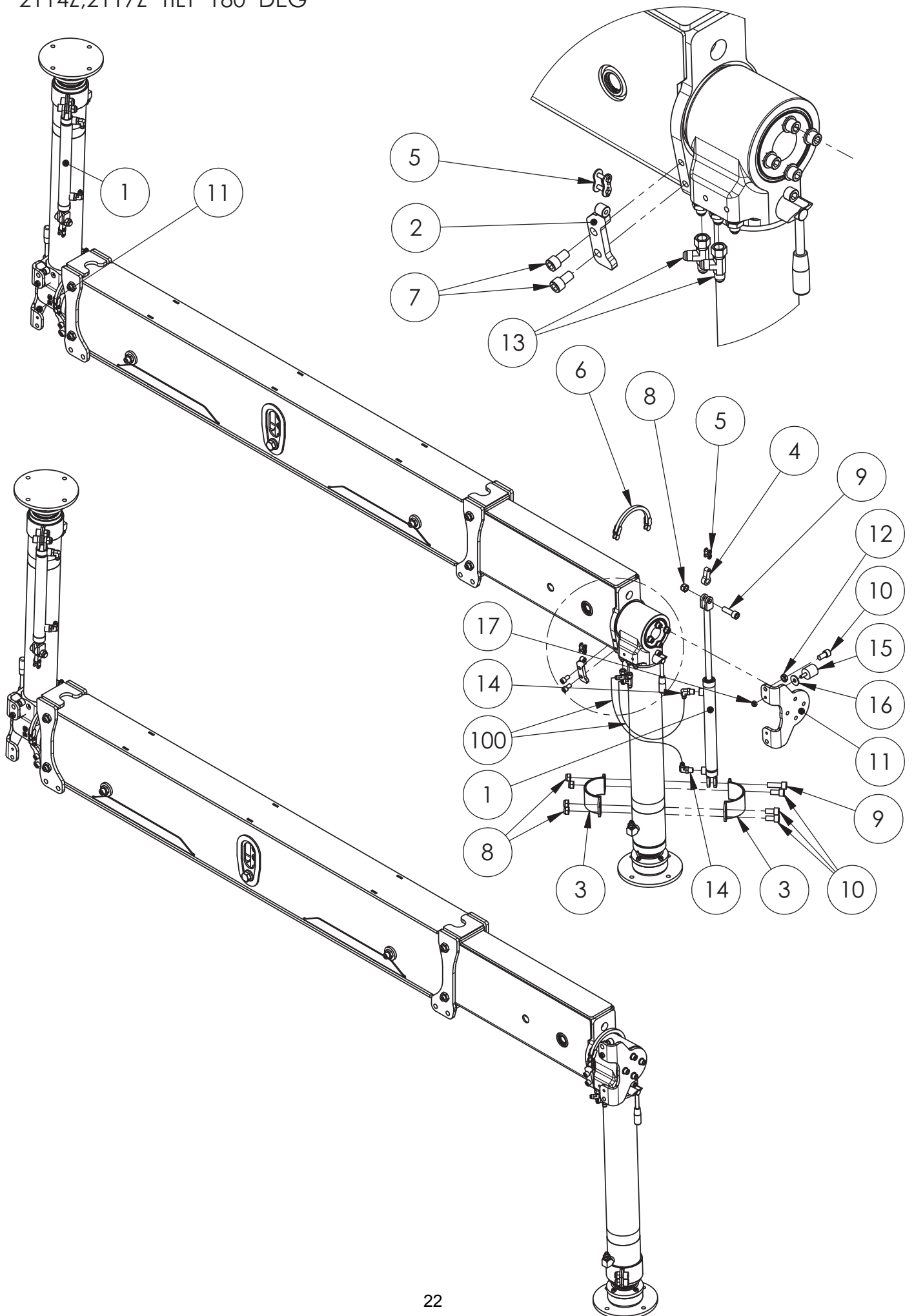

Item code	90025356	Revision	B
Title	STABILIZER	Date	13.02.2012
Specification	TILT 180 DEG		

Pos	Item code	Title	Specification	Pc	Nto Weight
1	28700001	CYLINDER	32/20X285	2	3.19
2	90025350	FASTENER		2	0.22
3	90025351	FASTENER		4	0.76
4	90025354	FASTENER		2	0.11
5	3190187	JOINT	12 B-1 ( R 3/4" )	4	0.02
6	3190188	CHAIN	12 B-1 ( R/4" ), 15 LENKKIÄ ( L=286 )	2	0.36
7	3010604	ALLEN SCREW	M12X20 8.8 DIN 912	4	0
8	3020010	NUT	M16 ZN DIN 985	10	0.03
9	3010282	ALLEN SCREW	M16X50 8.8 ZN DIN 912	4	0
10	3010700	ALLEN SCREW	M16X30 8.8 ZN DIN 912	8	0
11	90025357	FLANGE		2	2.41
12	3020015	NUT	M16 ZN DIN 936	2	0
13	3091229	CONNECTOR	1230-06-06-06	4	0.08
14	3091358	CONNECTOR	6310-06-06	4	0.09
15	3301887	DAMPER	40/40XM10 NR55 (509187,SIMRIT)	2	0.06
16	3030105	WASHER	M12 ZN DIN 9021	2	0.02
17	3020004	NUT	M10 ZN DIN 985	2	0.01
100	3133117	HYDRAULIC HOSE	A50005-06-06/241T-06/A50054-06-06/L=670 TEX	4	

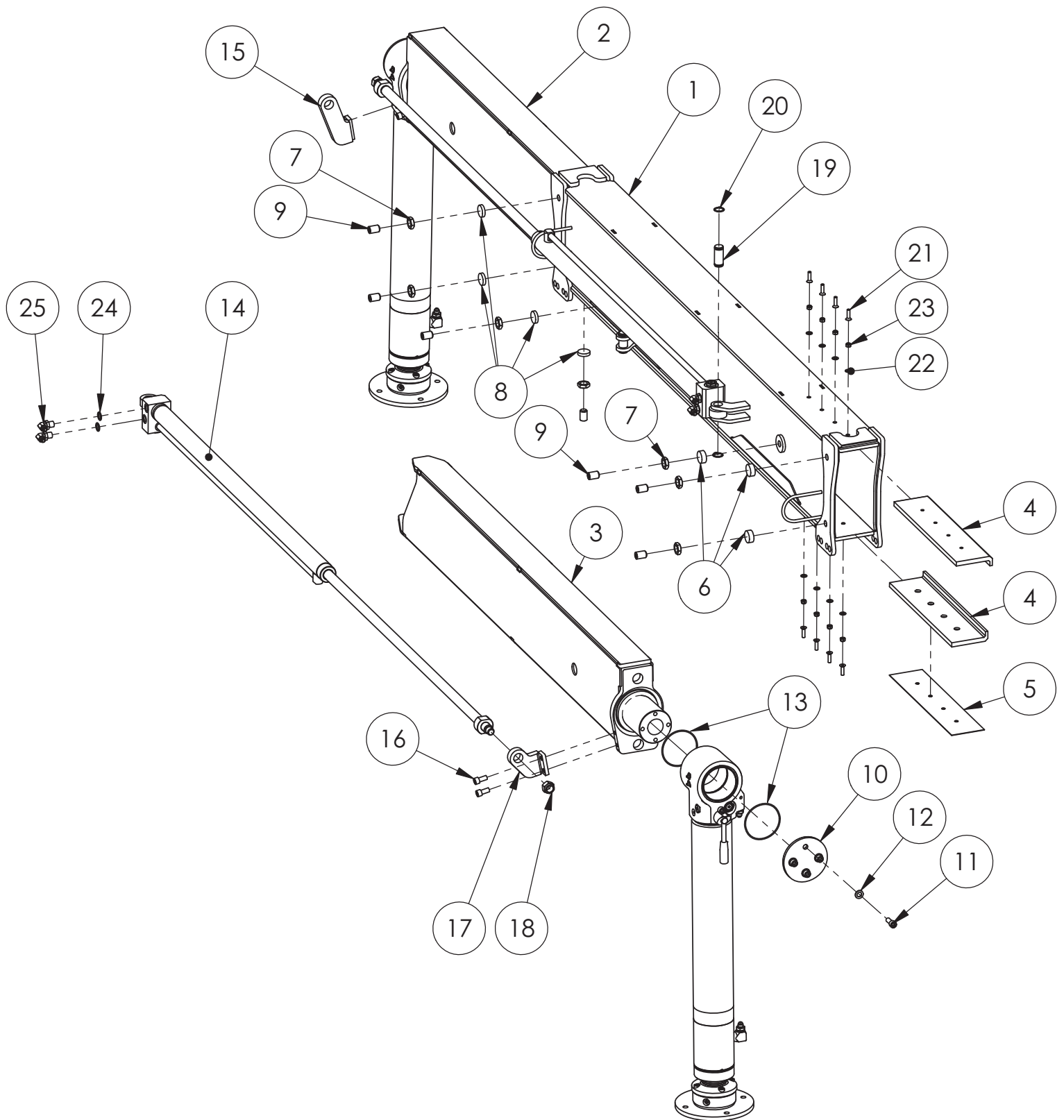



Item code	90026347	Revision	-
Title	STABILIZER	Date	02.05.2013
Specification	L=4770		

Pos	Item code	Title	Specification	Pc	Nto Weight
1	90026348	BEAM	SUPPORT BEAM	1	115.32
2	90026349	CONTROL ARM	OUTER	1	68.65
3	90026358	CONTROL ARM	INNER	1	66.94
4	90026360	GLIDE PAD	112X455	2	0.81
5	90026370	SHIM	1X102X455	1	0.36
6	90026231	GLIDE PAD	35-14	3	0.02
7	3020014	NUT	M20 ZN DIN 936	7	0
8	90020807	GLIDE PAD	35 - 8	4	0.01
9	3010312	ALLEN SCREW	M20X30 10.9 ZN DIN 913	7	0
10	90011250	FLANGE	135 - 8	2	0.86
11	3010246	ALLEN SCREW	M12X30 8.8 ZN DIN 912	8	0
12	3030047	WASHER	M12/13 ZN DIN 126	8	0.01
13	3110259	O-RING	104.5X3 90 SHORE	4	0.02
14	28958001	SPREADING CYLINDER	40/28X1100	2	17.39
15	90026355	BRACKET		1	1.35
16	3010239	ALLEN SCREW	M12X25 8.8 ZN DIN 912	4	0
17	90026365	BRACKET		1	0.96
18	3020009	NUT	M20 ZN DIN 985	2	0.07
19	90013830	AXLE	25-60	2	0.23
20	3060007	SNAP RING	25 ZN DIN 471	4	0
21	3010176	ALLEN SCREW	M8X30 10.9 ZN DIN 7991	8	0
22	3030025	WASHER	M8 ZN DIN 126	8	0
23	3020001	NUT	M8 ZN DIN 985	8	0.01
24	3110040	USIT-SEAL	R-06 R 3/8"	4	0
25	3091358	CONNECTOR	6310-06-06	4	0.09

90025044  
L=3620

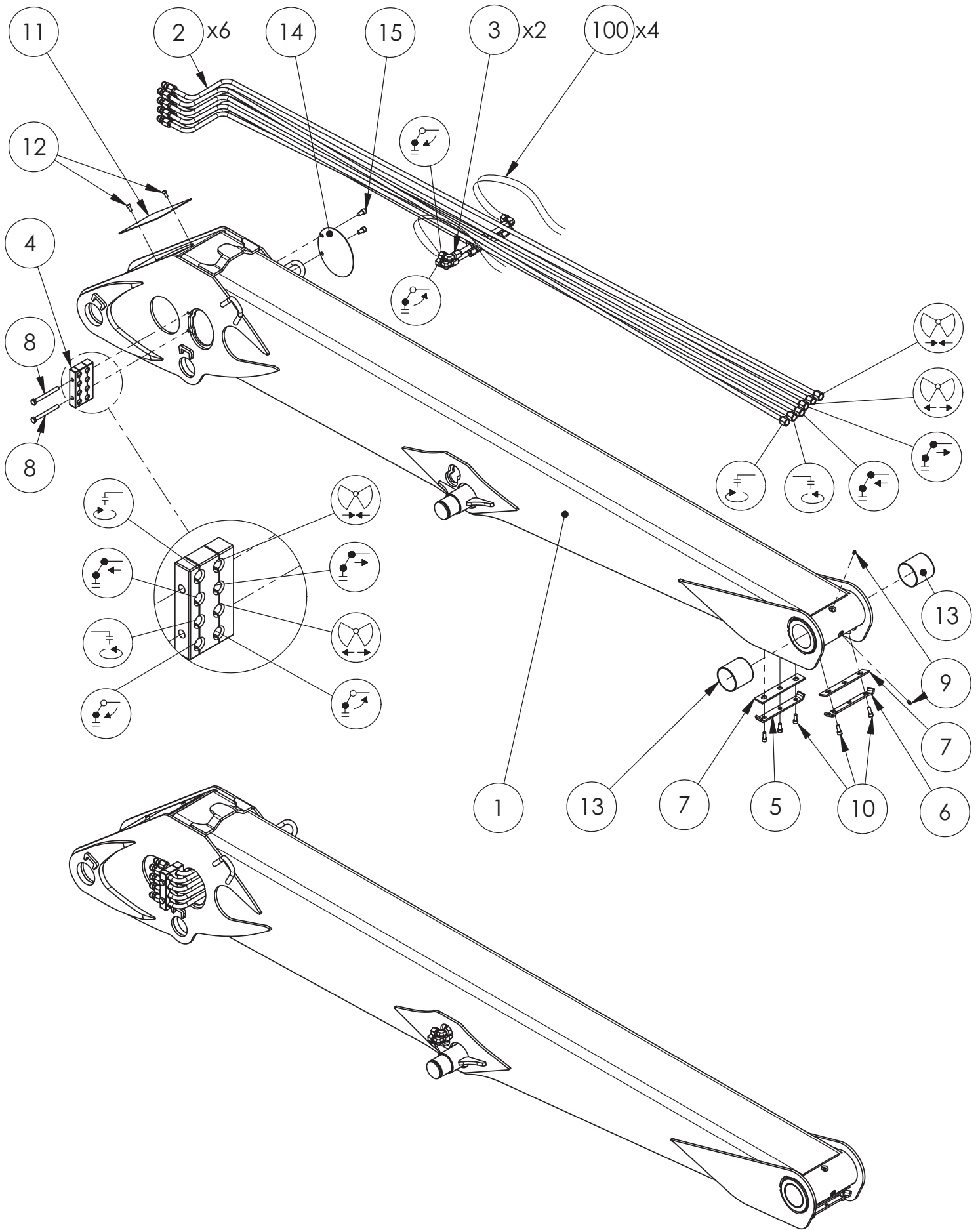

Item code	90025044	Revision	-
Title	LIFT BOOM	Date	27.10.2011
Specification	L=3620 VAR		

Pos	Item code	Title	Specification	Pc	Nto Weight
1	90025032	LIFT BOOM	L=3620 HITS+KON	1	307.51
2	90024323	HYDRAULIC PIPE	1 KOK	6	2.75
3	90024331	HYDRAULIC PIPE	2. BOOM CYLINDER	2	2.87
4	90024321	FASTENER	D = 16	1	1.01
5	90013744	FASTENER		1	0.32
6	90015473	FASTENER		1	0.32
7	90013489	RUBBER	5X40X220	2	0.06
8	3010122	HEW SCREW	M12X120 8.8 ZN DIN 931	2	0
9	3050003	GREASE NIPPLE	M8X1,25 DIN 71412	2	0
10	3010685	ALLEN SCREW	M10X25 8.8 ZN DIN 912	5	0
11	90023441	COVER		1	0.76
12	3010292	ALLEN SCREW	M8X16 8.8 ZN DIN 912	2	0
13	3100382	BUSHING	WB 802 9090	2	0.51
14	90025045	COVER		1	0.44
15	3010604	ALLEN SCREW	M12X20 8.8 DIN 912	2	0
100	3132975	HYDRAULIC HOSE	A50005-10-08/241T-08/500200-10-08/L=750	4	

90025205

L=3100

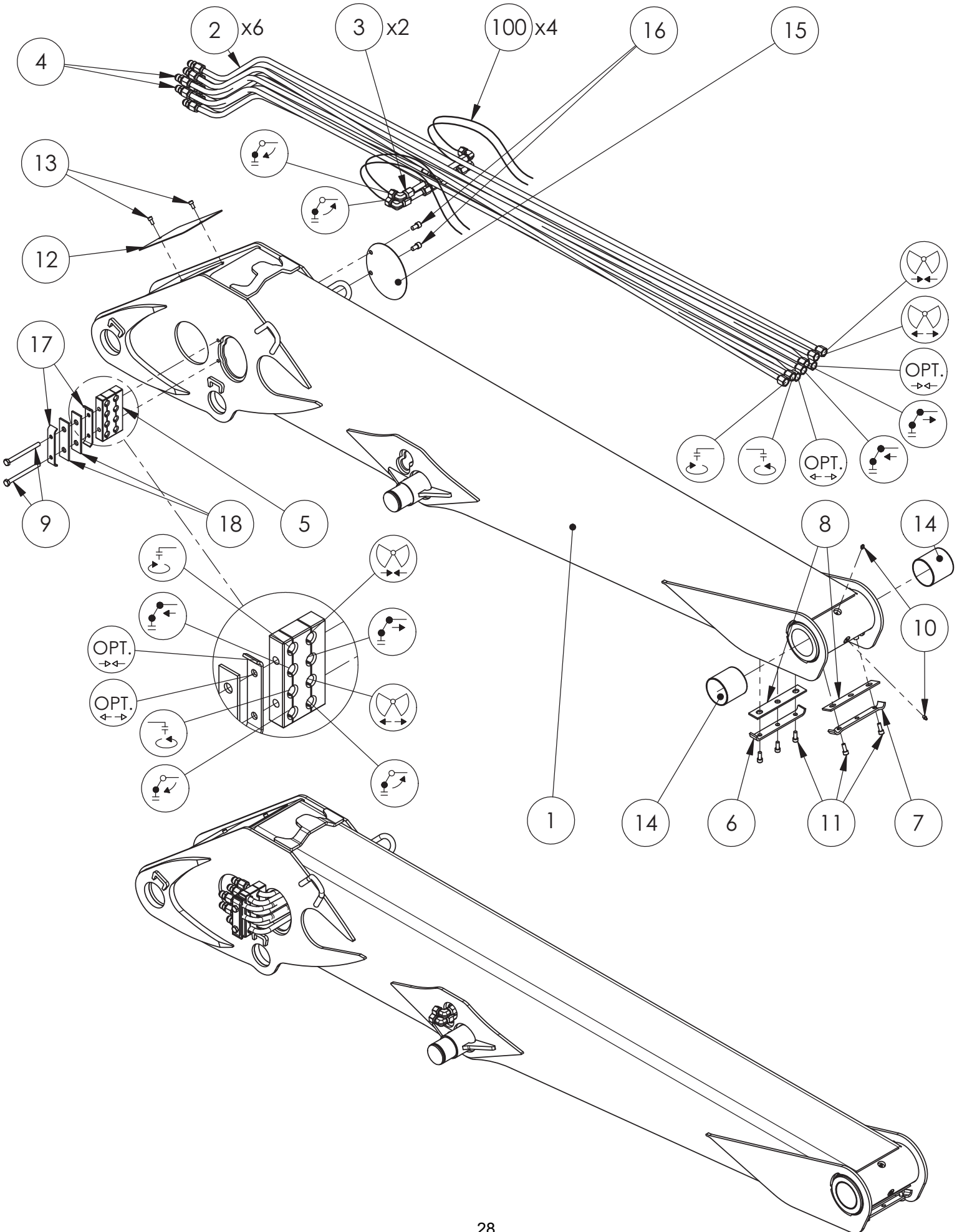

Item code	90025205	Revision	-
Title	LIFT BOOM	Date	19.12.2011
Specification	3100 RIGHT VAR		

Pos	Item code	Title	Specification	Pc	Nto Weight
1	90025202	LIFT BOOM	L=3100 HITS+KON	1	279.16
2	90025209	HYDRAULIC PIPE	1 KOK	6	2.09
3	90025211	HYDRAULIC PIPE	SIIRTOSYL KOK	2	2.51
4	90025302	HYDRAULIC PIPE	2 KOK	2	2.09
5	90024321	FASTENER	D = 16	1	1.01
6	90013744	FASTENER		1	0.32
7	90015473	FASTENER		1	0.32
8	90013489	RUBBER	5X40X220	2	0.06
9	3010332	HEW SCREW	M12X140 8.8 ZN DIN 931	2	0
10	3050003	GREASE NIPPLE	M8X1,25 DIN 71412	2	0
11	3010685	ALLEN SCREW	M10X25 8.8 ZN DIN 912	5	0
12	90023441	COVER		1	0.76
13	3010292	ALLEN SCREW	M8X16 8.8 ZN DIN 912	2	0
14	3100382	BUSHING	WB 802 9090	2	0.51
15	90025045	COVER		1	0.44
16	3010604	ALLEN SCREW	M12X20 8.8 DIN 912	2	0
17	90012248	FASTENER	4X30-152	2	0.14
18	90010444	RUBBER	5X40-145	2	0.04
100	3132975	HYDRAULIC HOSE	A50005-10-08/241T-08/500200-10-08/L=750	4	

90025143  
L = 4700

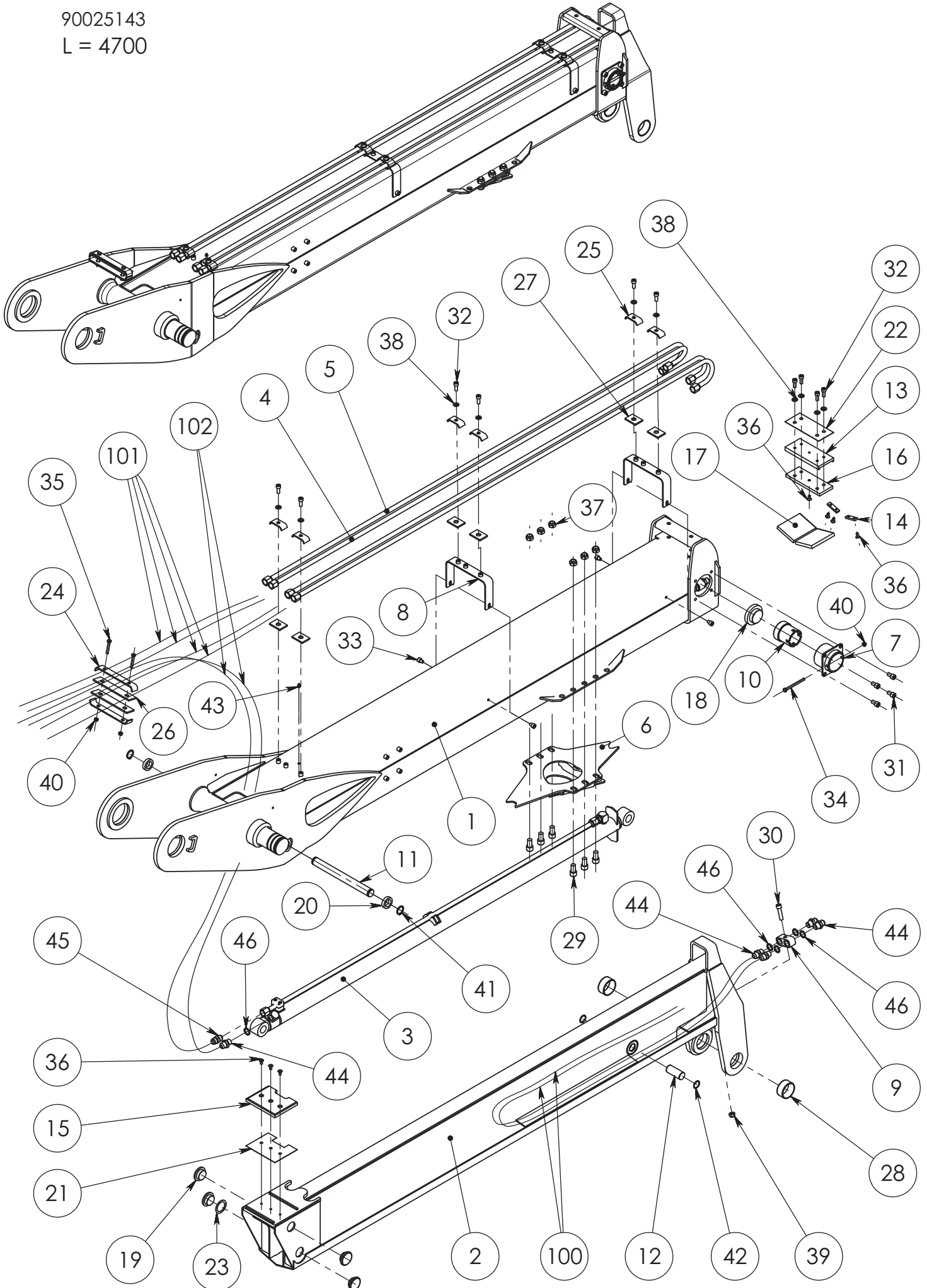

Item code	90025143	Revision	B
Title	OUTER BOOM	Date	02.12.2011
Specification	L=4700 1-JATK		

Pos	Item code	Title	Specification	Pc	Nto Weight
1	90025108	OUTER BOOM	L=2940	1	202.02
2	90025125	EXTENSION	L=2450 HITS+KON	1	109.21
3	90021354	CYLINDER	50/30 X 1650	1	28.91
4	90021405	PIPE	L=2324 KOK	2	1.75
5	90021407	PIPE	L=2365 KOK	2	1.77
6	90021531	RACK	HITS	1	6.75
7	90021394	FASTENER	HITS	2	1.31
8	90025766	FASTENER	L=204 HITS	2	0.56
9	90021408	CONNECTOR	R 1/2"	2	0.35
10	90021396	FASTENER		2	0.85
11	90018765	AXLE	30-304	1	1.68
12	90022463	AXLE	30-71	1	0.39
13	90020556	FASTENER	L-180	1	1.18
14	90010345	HOLDER		2	0.03
15	90014887	GLIDE PAD	120X155	1	0.24
16	90020563	GLIDE PAD	70X180	1	0.17
17	90014768	GLIDE PAD	12 X 90 X 120	2	0.15
18	90021397	GLIDE PAD	56X80-15X15	2	0.13
19	90011001	GLIDE PAD	D=55-19/7	4	0.03
20	90025804	SLEEVE	40/31-11	2	0.01
21	90017085	PLATE	119X155	1	0.13
22	90020567	PLATE	80X180	1	0.11
23	21039422	SHIM	1XD=55	1	0.01
24	90021958	FASTENER	4X30-215	2	0.2
25	90010442	FASTENER	LT4X30-72	6	0.07
26	90021961	RUBBER	5X40-190	2	0.05
27	90010443	RUBBER	5X55-40	6	0.01
28	3100225	BUSHING	WB 802 6030	2	0.11
29	3010700	ALLEN SCREW	M16X30 8.8 ZN DIN 912	6	0
30	3010580	ALLEN SCREW	M12X50 8.8 ZN DIN 912	2	0
31	3010604	ALLEN SCREW	M12X20 8.8 DIN 912	8	0
32	3010685	ALLEN SCREW	M10X25 8.8 ZN DIN 912	10	0
33	3010297	ALLEN SCREW	M10X12 8.8 ZN DIN 912	4	0
34	3010447	HEW SCREW	M8X100 8.8 ZN DIN 931	2	0
35	3010072	HEW SCREW	M8X50 8.8 ZN DIN 931	2	0
36	3010190	ALLEN SCREW	M8X16 10.9 DIN 7991	8	0

Item code	90025143	Revision	B
Title	OUTER BOOM	Date	02.12.2011
Specification	L=4700 1-JATK		

Pos	Item code	Title	Specification	Pc	Nto Weight
37	3020010	NUT	M16 ZN DIN 985	6	0.03
38	3030003	WASHER	M10/11 ZN DIN 126	10	0
39	3020005	NUT	M12 ZN DIN 985	2	0.02
40	3020001	NUT	M8 ZN DIN 985	4	0.01
41	3060092	SNAP RING	AS 30X2 ZN DIN 471	2	0
42	3060019	SNAP RING	30 DIN 472	2	0
43	3050003	GREASE NIPPLE	M8X1,25 DIN 71412	1	0
44	3090917	CONNECTOR (STRAIGHT)	26-040010810 R 1/2" -7/8" JIC	9	0.11
45	3090654	CONNECTOR	1010-10-10	1	0.09
46	3110042	USIT-SEAL	R-08 R 1/2"	9	0.01
100	3132972	HYDRAULIC HOSE	A50005-10-08/241X-08/500200-10-08/L=2200	4	0
101	3132973	HYDRAULIC HOSE	500200-10-08/241T-08/500200-10-08/L=1100	4	
102	3133073	HYDRAULIC HOSE	500200-10-08/241T-08/A50064-10-08/L=1100	2	



90025214

L= 4835

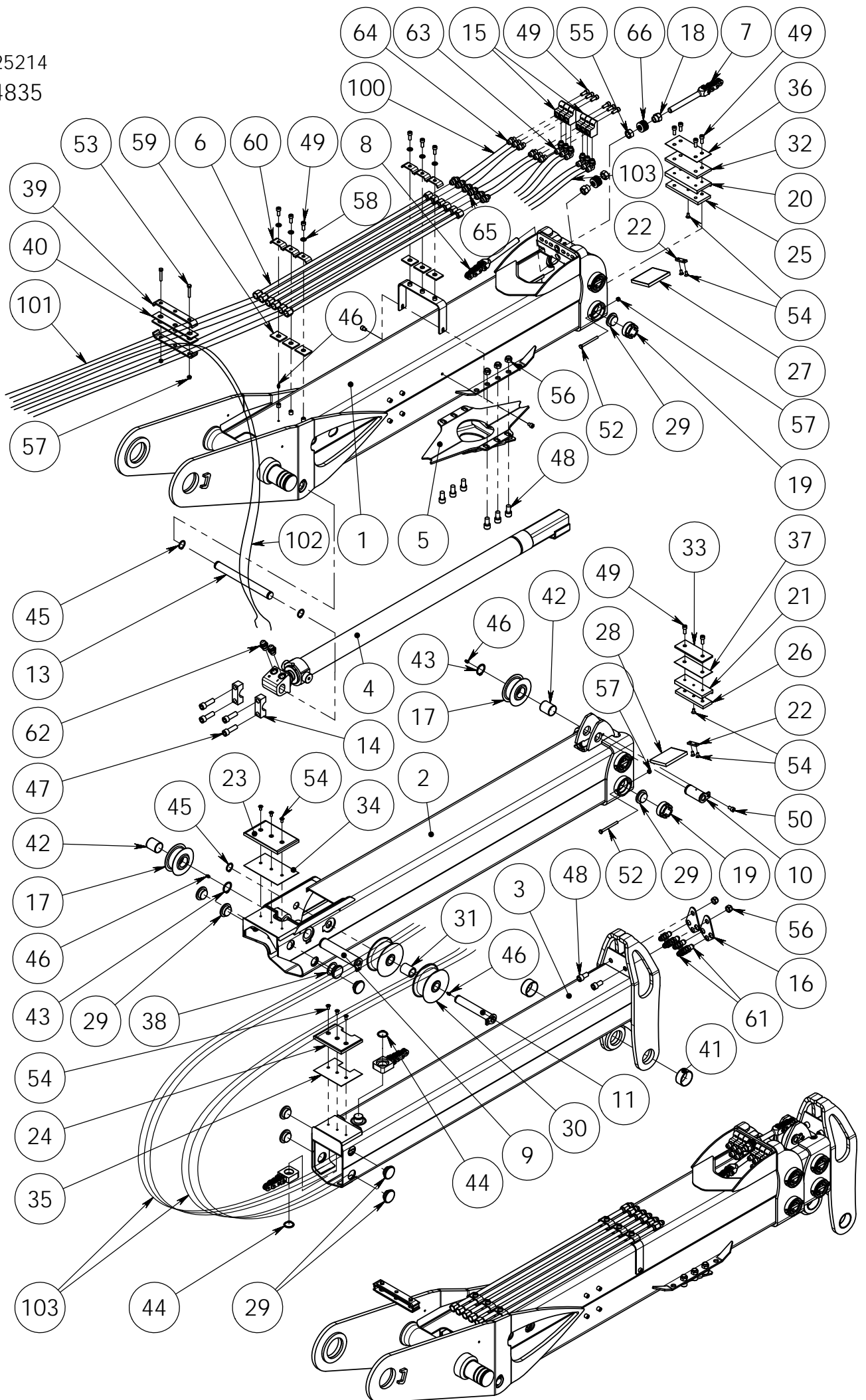

Item code	90025214	Revision	D
Title	OUTER BOOM	Date	21.12.2011
Specification	L=4835 / 6-HOSES		

Pos	Item code	Title	Specification	Pc	Nto Weight
1	90025215	OUTER BOOM	L=2385	1	177.54
2	90025218	EXTENSION 1	L=1990	1	81.53
3	90025221	EXTENSION 2	L=1710	1	64.41
4	28892001	EXTENSION CYLINDER	70/40X1100	1	34.27
5	90021531	RACK	HITS	1	6.75
6	90025224	PIPE	L=960	6	0.8
7	90025288	CHAIN	3X4 ( 59 LENKKIÄ ) KOK	1	1.51
8	90025290	CHAIN	3X4 ( 69 LENKKIÄ ) KOK	1	1.51
9	90023019	AXLE	40-203	1	1.94
10	90023021	AXLE	40-88	1	0.82
11	90023024	AXLE	30-203	1	1.07
12	90025729	FASTENER	L=224 HITS ZN	1	0.61
13	90018765	AXLE	30-304	1	1.68
14	90019106	COVER		2	0.37
15	90023027	CONNECTOR	R 3/8"	6	0.31
16	90019118	FASTENER	R / JIC	2	0.14
17	90021697	WHEEL	R1", 3X4, D90	2	1.96
18	90017520	NUT	M20-30	2	0.09
19	90016090	FASTENER		8	0.35
20	90020556	FASTENER	L-180	1	1.18
21	90023050	FASTENER		1	0.77
22	90010345	HOLDER		4	0.03
23	90020561	GLIDE PAD	120X190	1	0.31
24	90014887	GLIDE PAD	120X155	1	0.24
25	90020563	GLIDE PAD	70X180	1	0.17
26	90023052	GLIDE PAD	12X50X155	1	0.08
27	90020562	GLIDE PAD	120X100	2	0.17
28	90014768	GLIDE PAD	12 X 90 X 120	2	0.15
29	90011001	GLIDE PAD	D=55-19/7	16	0.03
30	90023054	ROLL		2	0.78
31	90024481	SLEEVE	40/31-48	1	0.02
32	90023238	PLATE		1	1.09
33	90023239	PLATE		1	0.43
34	90020566	PLATE	119X190	1	0.18
35	90017085	PLATE	119X155	1	0.13
36	90020567	PLATE	80X180	1	0.11

Item code	90025214	Revision	D
Title	OUTER BOOM	Date	21.12.2011
Specification	L=4835 / 6-HOSES		

Pos	Item code	Title	Specification	Pc	Nto Weight
37	90023240	PLATE	60 X 155	1	0.07
38	21039422	SHIM	1XD=55	1	0.01
39	90013744	FASTENER		2	0.32
40	90013489	RUBBER	5X40X220	2	0.06
41	3100225	BUSHING	WB 802 6030	2	0.11
42	3100188	BUSHING	WB 802 4050	2	0.1
43	3060100	SNAP RING	AS 40X2.5 ZN DIN 471	2	0
44	3060091	SNAP RING	AS 35X2.5 ZN DIN 471	2	0.01
45	3060092	SNAP RING	AS 30X2 ZN DIN 471	3	0
46	3050003	GREASE NIPPLE	M8X1,25 DIN 71412	4	0
47	3010301	ALLEN SCREW	M16X50 12.9 DIN 912	4	0
48	3010700	ALLEN SCREW	M16X30 8.8 ZN DIN 912	8	0
49	3010685	ALLEN SCREW	M10X25 8.8 ZN DIN 912	18	0
50	3010898	ALLEN SCREW	M10X16 8.8 ZN DIN 912	1	0
51	3010297	ALLEN SCREW	M10X12 8.8 ZN DIN 912	2	0
52	3010328	HEW SCREW	M8X90 8.8 ZN DIN 931	8	0
53	3010072	HEW SCREW	M8X50 8.8 ZN DIN 931	2	0
54	3010190	ALLEN SCREW	M8X16 10.9 DIN 7991	16	0
55	3020032	NUT	M20 ZN DIN 934/8	2	0
56	3020010	NUT	M16 ZN DIN 985	8	0.03
57	3020001	NUT	M8 ZN DIN 985	10	0.01
58	3030003	WASHER	M10/11 ZN DIN 126	6	0
59	90010443	RUBBER	5X55-40	6	0.01
60	90010442	FASTENER	LT4X30-72 ZN	6	0.07
61	3090952	CONNECTOR	29-1030-08-08	6	0.11
62	3090289	CONNECTOR	29-6010-08-10	2	0.11
63	3090630	CONNECTOR (ANGLE)	6310-06-08	6	0.1
64	3090604	CONNECTOR	6010-06-08	6	0.07
65	3090907	CONNECTOR	1010-08-10	6	0.1
66	3300150	SPRING	40X20.4X2.5 SF-TAF DIN 2093	16	0
100	3133105	HYDRAULIC HOSE	A50005-08-06/241T-06/A50005-08-06/L=550	6	
101	3132998	HYDRAULIC HOSE	500200-10-08/241T-08/500200-10-08/L=1000	6	
102	3133073	HYDRAULIC HOSE	500200-10-08/241T-08/A50064-10-08/L=1100	2	
103	3133106	HYDRAULIC HOSE	A50005-08-06/241T-06/A50005-08-06/L=3130	6	0

90025077

L= 5995

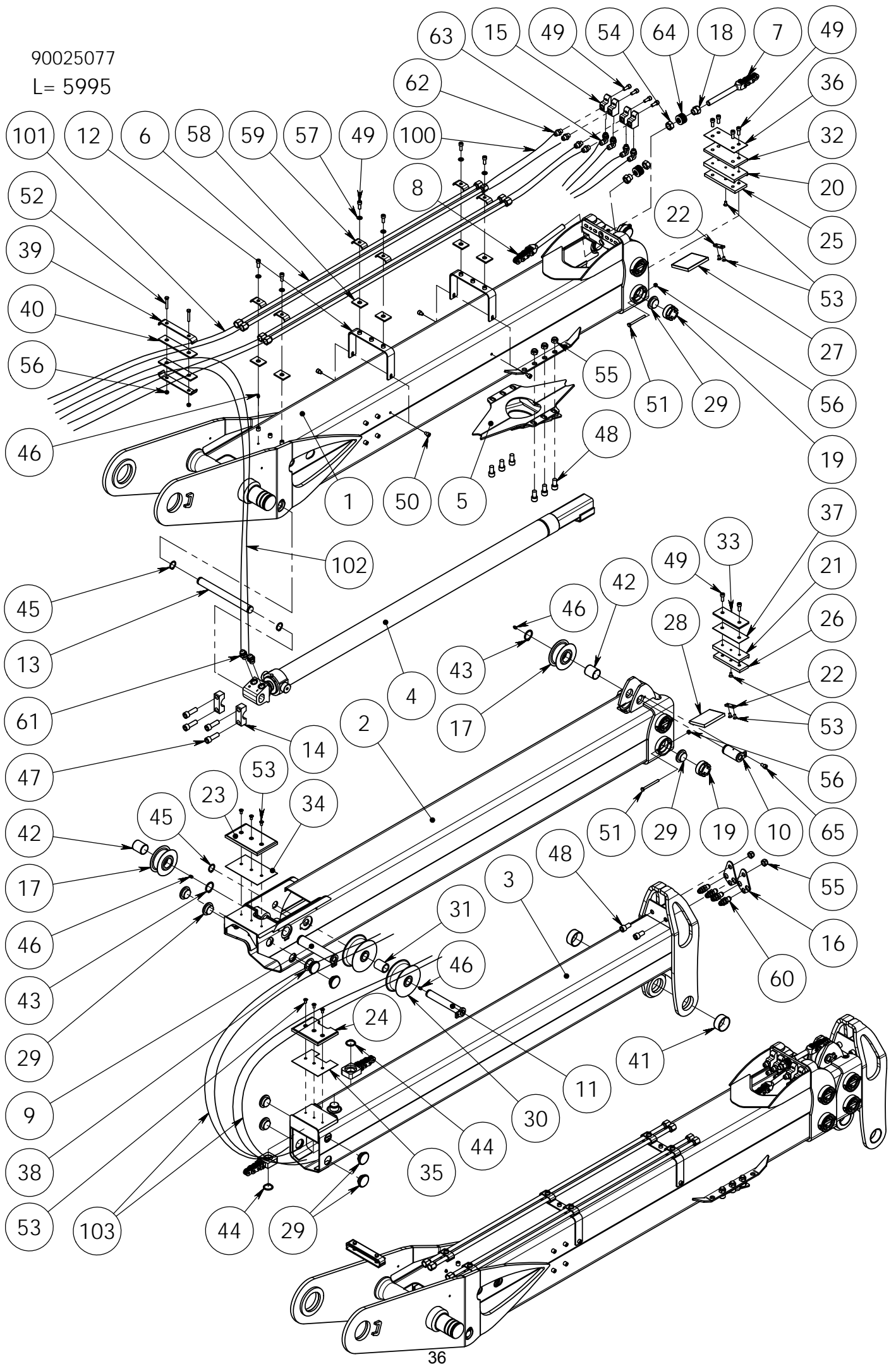

Item code	90025077	Revision	C
Title	OUTER BOOM	Date	04.11.2011
Specification	L=5995		

Pos	Item code	Title	Specification	Pc	Nto Weight
1	90025053	OUTER BOOM	L=2845	1	195.4
2	90025063	EXTENSION	1 HITS	1	97.17
3	90025069	EXTENSION	L=2170	1	76.23
4	28658001	CYLINDER	70/40X1450	1	40.35
5	90021531	RACK	HITS	1	6.75
6	90021148	PIPE	L=1420	4	1.12
7	90021171	CHAIN	3X4 (77 LENKKIÄ)	1	1.51
8	90021172	CHAIN	3X4 (87 LENKKIÄ)	1	1.51
9	90023019	AXLE	40-203	1	1.94
10	90023021	AXLE	40-88	1	0.82
11	90023024	AXLE	30-203	1	1.07
12	90025729	FASTENER	L=224 HITS ZN	2	0.61
13	90018765	AXLE	30-304	1	1.68
14	90019106	COVER		2	0.37
15	90023027	CONNECTOR	R 3/8"	4	0.31
16	90019118	FASTENER	R / JIC	2	0.14
17	90021697	WHEEL	R1", 3X4, D90	2	1.96
18	90017520	NUT	M20-30	2	0.09
19	90016090	FASTENER		8	0.35
20	90020556	FASTENER	L-180	1	1.18
21	90023050	FASTENER		1	0.77
22	90010345	HOLDER		4	0.03
23	90020561	GLIDE PAD	120X190	1	0.31
24	90014887	GLIDE PAD	120X155	1	0.24
25	90020563	GLIDE PAD	70X180	1	0.17
26	90023052	GLIDE PAD	12X50X155	1	0.08
27	90020562	GLIDE PAD	120X100	2	0.17
28	90014768	GLIDE PAD	12 X 90 X 120	2	0.15
29	90011001	GLIDE PAD	D=55-19/7	16	0.03
30	90023054	ROLL		2	0.78
31	90024481	SLEEVE	40/31-48	1	0.02
32	90023238	PLATE		1	1.09
33	90023239	PLATE		1	0.43
34	90020566	PLATE	119X190	1	0.18
35	90017085	PLATE	119X155	1	0.13
36	90020567	PLATE	80X180	1	0.11

Item code	90025077	Revision	C
Title	OUTER BOOM	Date	04.11.2011
Specification	L=5995		

Pos	Item code	Title	Specification	Pc	Nto Weight
37	90023240	PLATE	60 X 155	1	0.07
38	21039422	SHIM	1XD=55	1	0.01
39	90021958	FASTENER	4X30-215	2	0.2
40	90021961	RUBBER	5X40-190	2	0.05
41	3100225	BUSHING	WB 802 6030	2	0.11
42	3100188	BUSHING	WB 802 4050	2	0.1
43	3060100	SNAP RING	AS 40X2.5 ZN DIN 471	2	0
44	3060091	SNAP RING	AS 35X2.5 ZN DIN 471	2	0.01
45	3060092	SNAP RING	AS 30X2 ZN DIN 471	3	0
46	3050003	GREASE NIPPLE	M8X1,25 DIN 71412	4	0
47	3010301	ALLEN SCREW	M16X50 12.9 DIN 912	4	0
48	3010700	ALLEN SCREW	M16X30 8.8 ZN DIN 912	8	0
49	3010685	ALLEN SCREW	M10X25 8.8 ZN DIN 912	16	0
50	3010297	ALLEN SCREW	M10X12 8.8 ZN DIN 912	4	0
51	3010328	HEW SCREW	M8X90 8.8 ZN DIN 931	8	0
52	3010072	HEW SCREW	M8X50 8.8 ZN DIN 931	2	0
53	3010190	ALLEN SCREW	M8X16 10.9 DIN 7991	16	0
54	3020032	NUT	M20 ZN DIN 934/8	2	0
55	3020010	NUT	M16 ZN DIN 985	8	0.03
56	3020001	NUT	M8 ZN DIN 985	10	0.01
57	3030003	WASHER	M10/11 ZN DIN 126	6	0
58	90010443	RUBBER	5X55-40	6	0.01
59	90010442	FASTENER	LT4X30-72 ZN	6	0.07
60	3090952	CONNECTOR	29-1030-08-08	4	0.11
61	3090289	CONNECTOR	29-6010-08-10	2	0.11
62	3090604	CONNECTOR	6010-06-08	4	0.07
63	3090630	CONNECTOR (ANGLE)	6310-06-08	4	0.1
64	3300150	SPRING	40X20.4X2.5 SF-TAF DIN 2093	16	0
65	3010898	ALLEN SCREW	M10X16 8.8 ZN DIN 912	1	0
100	3132997	HYDRAULIC HOSE	A50005-08-08/241T-08/500200-10-08/L=600	4	
101	3132998	HYDRAULIC HOSE	500200-10-08/241T-08/500200-10-08/L=1000	4	
102	3133073	HYDRAULIC HOSE	500200-10-08/241T-08/A50064-10-08/L=1100	2	
103	3133538	HYDRAULIC HOSE	A50005-08-06/241T-06/A50005-08-06/L=4050	4	0

Item code	90025077	Revision	B
Title	OUTER BOOM	Date	04.11.2011
Specification	L=5995		

Pos	Item code	Title	Specification	Pc	Nto Weight
102	3133073	HYDRAULIC HOSE	500200-10-08/241T-08/A50064-10-08/L=1100	2	
103	3132999	HYDRAULIC HOSE	A50005-10-08/261E-08/A50005-10-08/L=4050	2	0
104	3133000	HYDRAULIC HOSE	A50005-08-06/261E-06/A50005-08-06/L=4050	2	

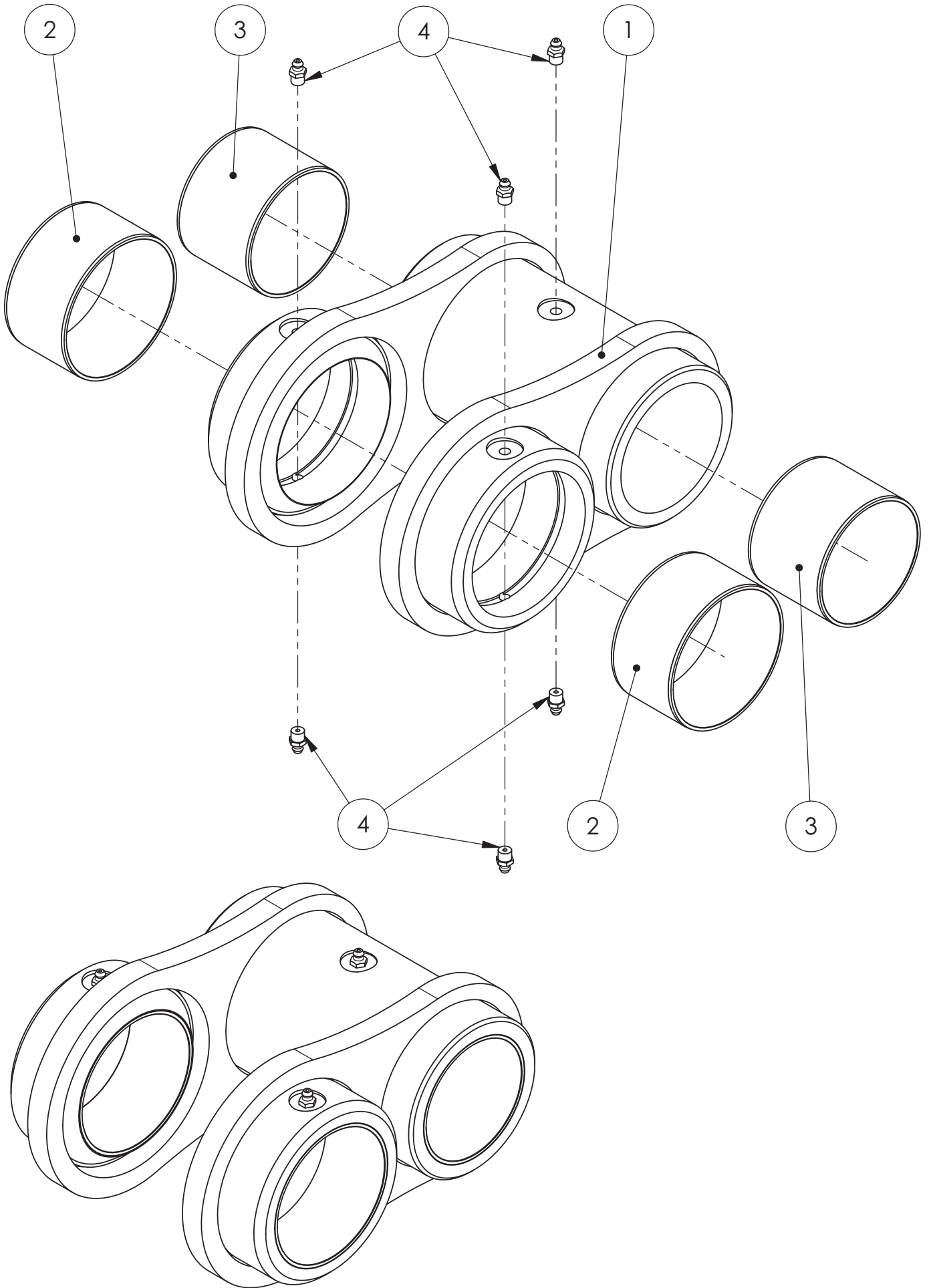



Item code	90024300	Revision	-
Title	DRAW BAR	Date	25.01.2011
Specification	VAR		

Pos	Item code	Title	Specification	Pc	Nto Weight
1	90024297	LINK	HITS+KON	1	10.08
2	3100380	BUSHING	WB 802 9050	2	0.28
3	3100226	BUSHING	WB 802 8060	2	0.3
4	3050003	GREASE NIPPLE	M8X1,25 DIN 71412	6	0

90025288  
3 x 4 / 59 LINKS

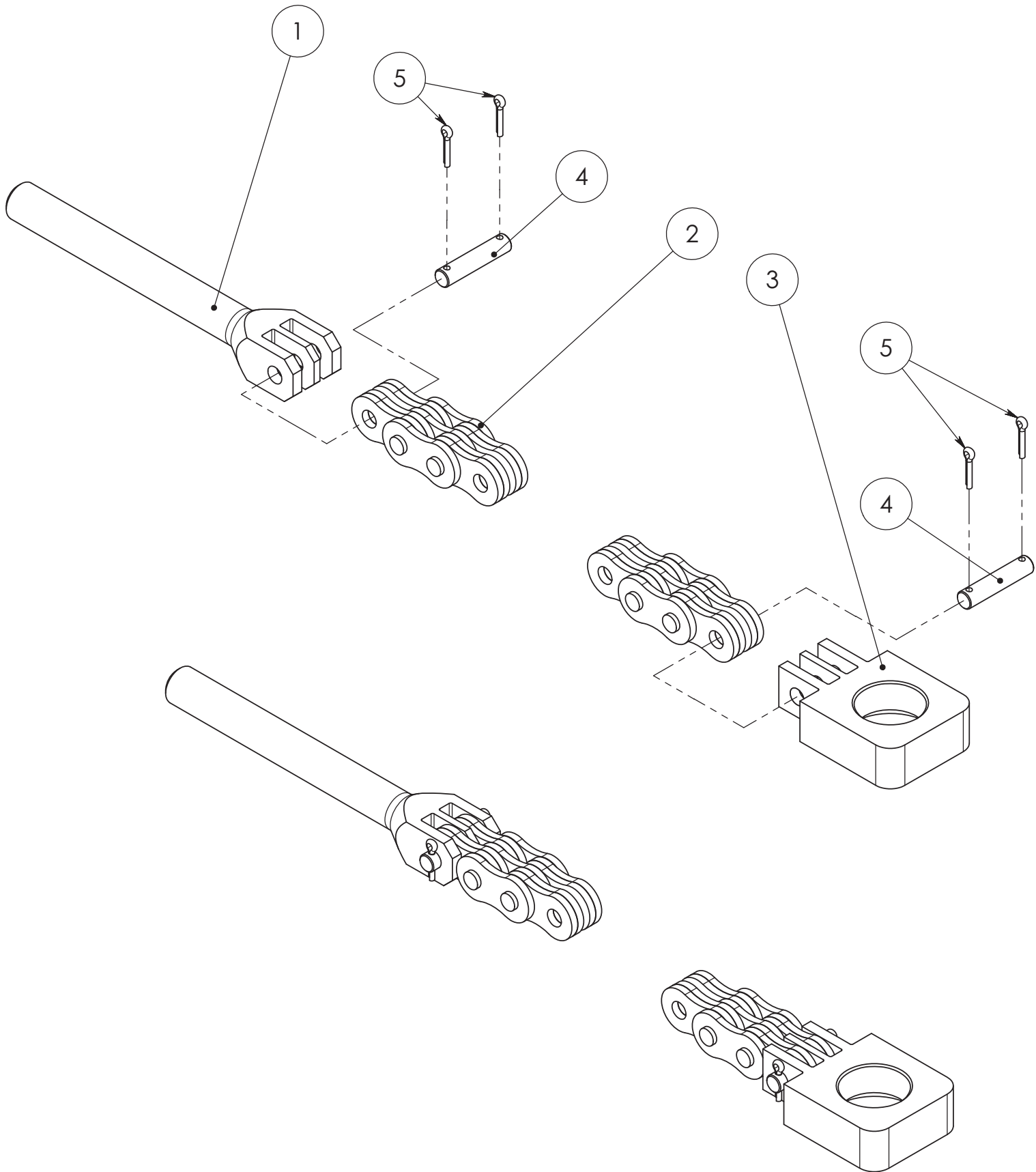

Item code	90025288	Revision	-
Title	CHAIN	Date	11.01.2012
Specification	3X4 ( 59 LENKKIÄ ) KOK		

Pos	Item code	Title	Specification	Pc	Nfo Weight
1	90021136	TENSIONER	R 1"	1	0.57
2	3190185	CHAIN	LH1634, DIN8152, R 1" L=1499 59 LENKKIÄ	1	0.33
3	90021137	CONNECTOR	R 1"	1	0.53
4	3190184	PIN	LIITINTAPPI D=9,53-43,7 KETJULLE BL834	2	0.02
5	3040060	COTTER PIN	3,2X20 ZN DIN 94	4	0

90025290

3 x 4 / 69 LINKS

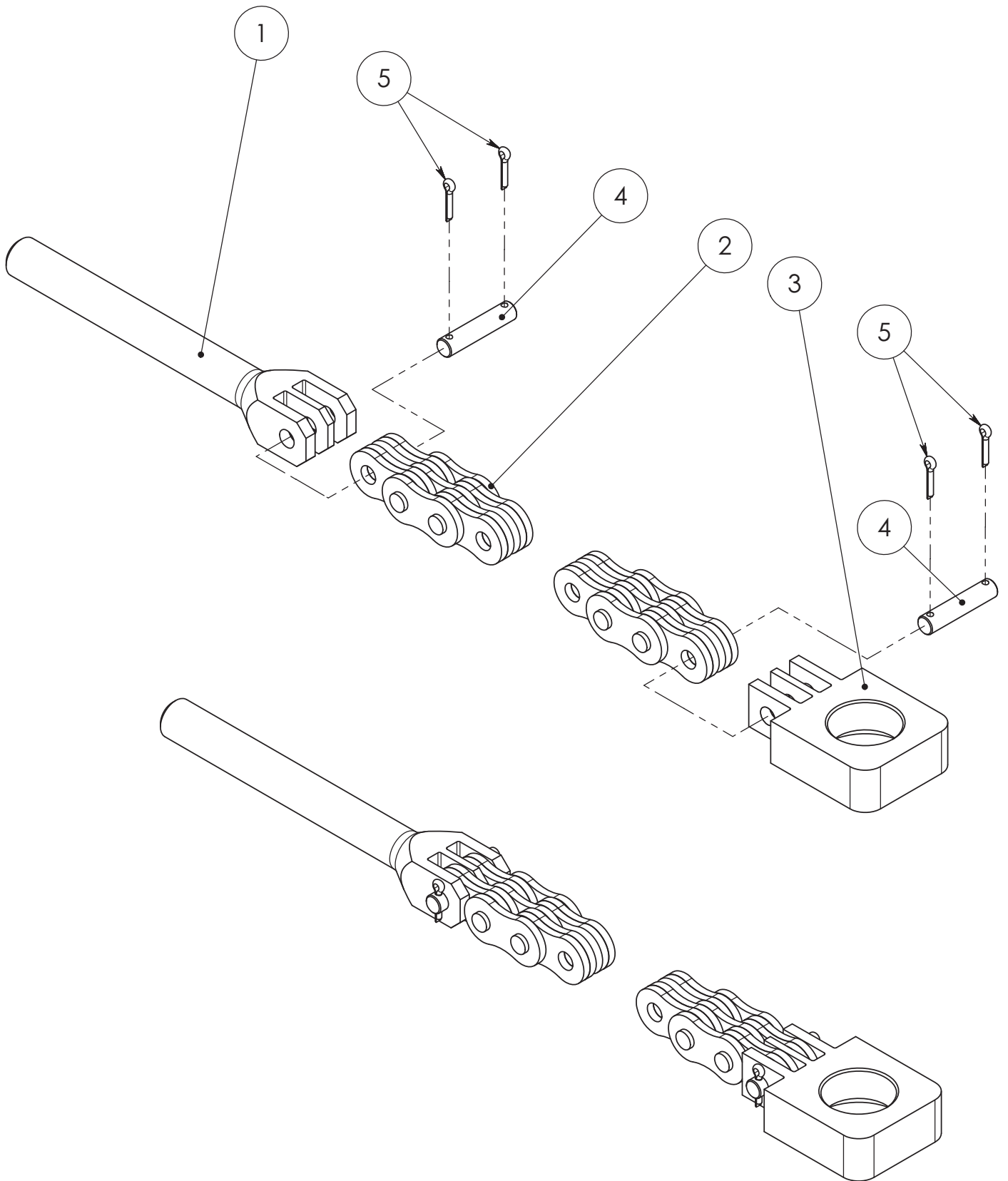

Item code	90025290	Revision	-
Title	CHAIN	Date	11.01.2012
Specification	3X4 ( 69 LENKKIÄ ) KOK		

Pos	Item code	Title	Specification	Pc	Nfo Weight
1	90021136	TENSIONER	R 1"	1	0.57
2	3190186	CHAIN	LH1634, DIN8152, R 1" L=1753 69 LENKKIÄ	1	0.33
3	90021137	CONNECTOR	R 1"	1	0.53
4	3190184	PIN	LIITINTAPPI D=9,53-43,7 KETJULLE BL834	2	0.02
5	3040060	COTTER PIN	3,2X20 ZN DIN 94	4	0

90025098  
140/90x970

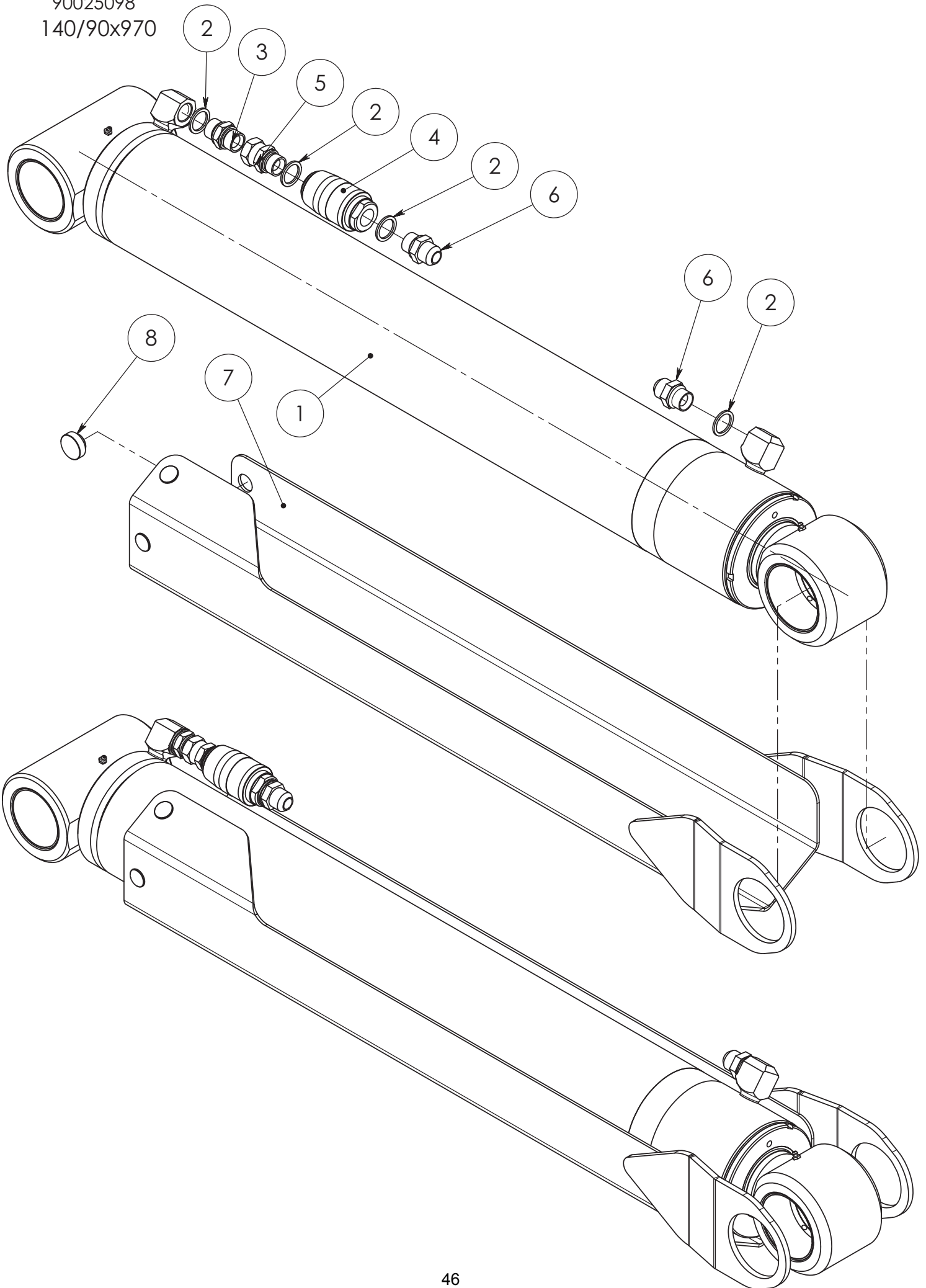

Item code	90025098	Revision	A
Title	CYLINDER	Date	17.11.2011
Specification	140 / 90 X 970 VAR		

Pos	Item code	Title	Specification	Pc	Nfo Weight
1	28890001	CYLINDER	140/90X970	1	111.96
2	3110130	USIT-SEAL	R-12 R 3/4"	4	0.01
3	3090185	CONNECTOR (STRAIGHT)	04000-12	1	0.14
4	3120235	CHECK VALVE		1	1.24
5	3090216	CONNECTOR (STRAIGHT)	04010-12-12	1	0.19
6	3090918	CONNECTOR (STRAIGHT)	R 3/4" -1 1/16" JIC 26-04001-12-12	2	0.16
7	90021460	COVER	2114Z/ 2117Z NOSTOSYL.	1	17.15
8	21038406	GLIDE PAD	35/25-16	5	0.01

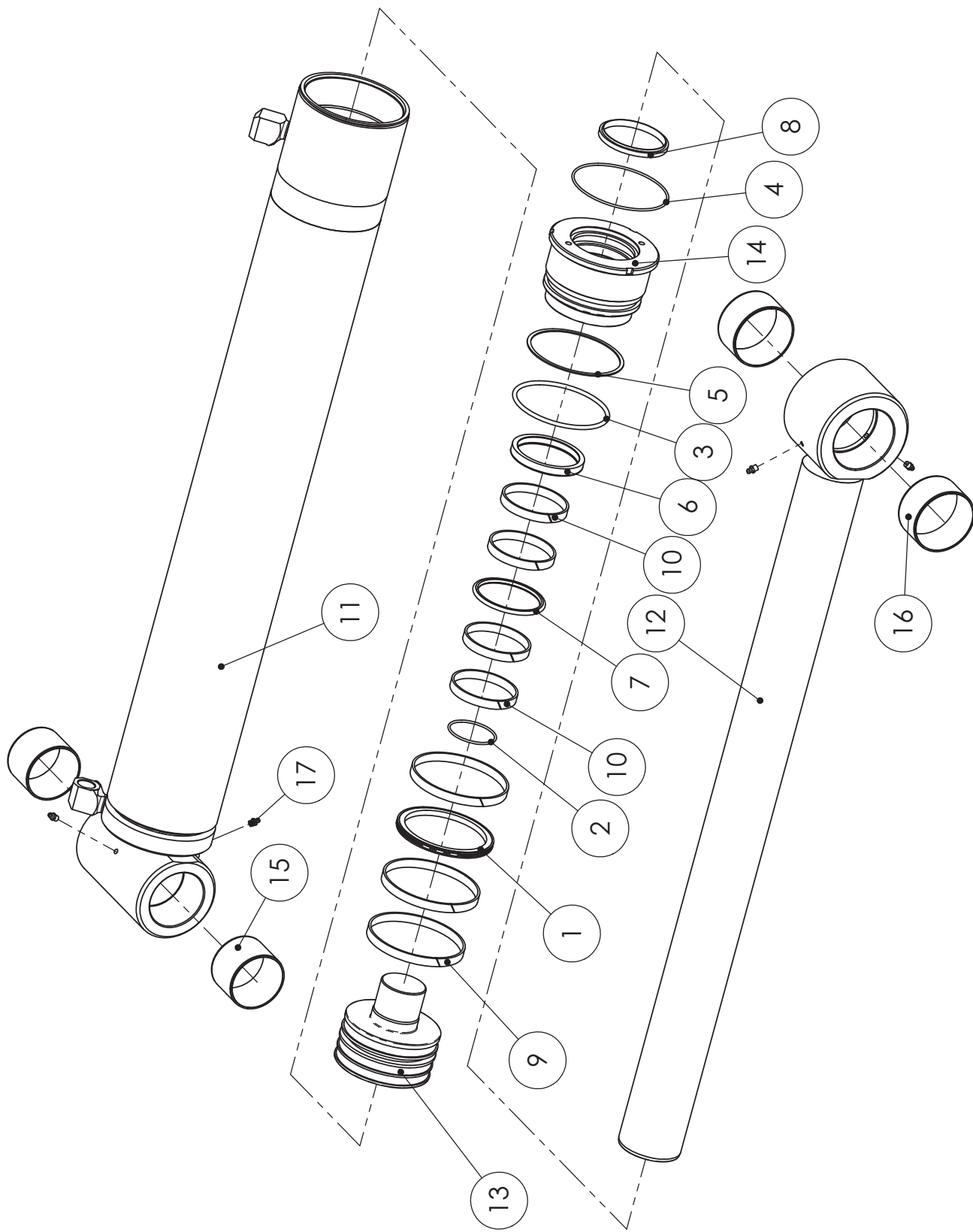

28890001 SYLINTERI

VARAOSAT \ RESERVDLAR \ SPARE PARTS \ ERSATZTEIL





## SPARE PART LIST

Item code	28890001	Revision	-
Title	SYLINTERI	Date	16.11.2012
Specification	140/90X970		

Pos	Item code	Title	Specification	Dimensions	Pc	Amount	Unit	Nto Weight
1	3110841	MÄNNÄNTIIVISTE KOLV TÄTNIING PISTON SEAL KOLBENDICHTUNG	OK 140/119X8		1			0.26
2	3110009	O-RENGAS O-RING O-RING O-RING	64.5X3 90 SHORE		1			0.01
3	3110201	O-RENGAS O-RING O-RING O-RING	129.3X5.7 70 SHORE		1			0.08
4	3110494	O-RENGAS O-RING O-RING O-RING	134.5X3 90 SHORE		1			0.02
5	3110202	TUKIRENGAS STÖDRING SUPPORTING RING STÜTZRING	140/130X1.7 PU		1			0
6	3110793	VARRENTIIVISTE KOLVSTÄNGSTÄTNIING ROD SEAL DICHTUNG FÜR KOLBENSTANGE	90/105X12		1			0.18
7	3110882	VARRENTIIVISTE KOLVSTÄNGSTÄTNIING ROD SEAL DICHTUNG FÜR KOLBENSTANGE	OMS-MR 90/105.1X6		1			0.09
8	3110420	LUOVUUTIN AYSTRYKARE WIPER SEAL ABSTREIFER	GA 90/100X7/10		1			0.09
9	3110687	MÄNNÄNOHJAIN KOLV STYRNING PISTON GUIDE KOLBENFÜHRUNG	E/PWR 140/134X13		3			0.13
10	3110795	OHJAIN STYRNING GUIDANCE STEUERUNG	I/PWR 90/96X13		4			0.09
11	28781101	SYLINTERIPUTKI CYLINDER RÖR CYLINDER BARREL ZYLINDERROHR	140 / 90 X 970		1			57.27
12	28890204	MÄNNÄNVARSI KOLVSTÄNG PISTON ROD KOLBENSTANGE	90		1			38.52
13	28890201	MÄNTÄ KOLV PISTON KOLBEN	140	L=134	1			7.21
14	28781202	OHJAIN STYRNING GUIDANCE STEUERUNG	140/90	L=103	1			6.32
15	3100226	LIUKULAAKERI BUSSNING BUSHING GLEITLAGER	WB 802 8060		2			0.3
16	3100380	LIUKULAAKERI BUSSNING BUSHING GLEITLAGER	WB 802 9050		2			0.28
17	3050003	RASVANIPPA SMÖRJNIPPEL GREASE NIPPLE SCHMIERNIPPEL	M8X1.25 DIN 71412		4			0
-10	3111007	TIIVISTESARJA TÄTNIINGSSATS SEAL KIT DICHTUNGSSATZ	140/90		1			

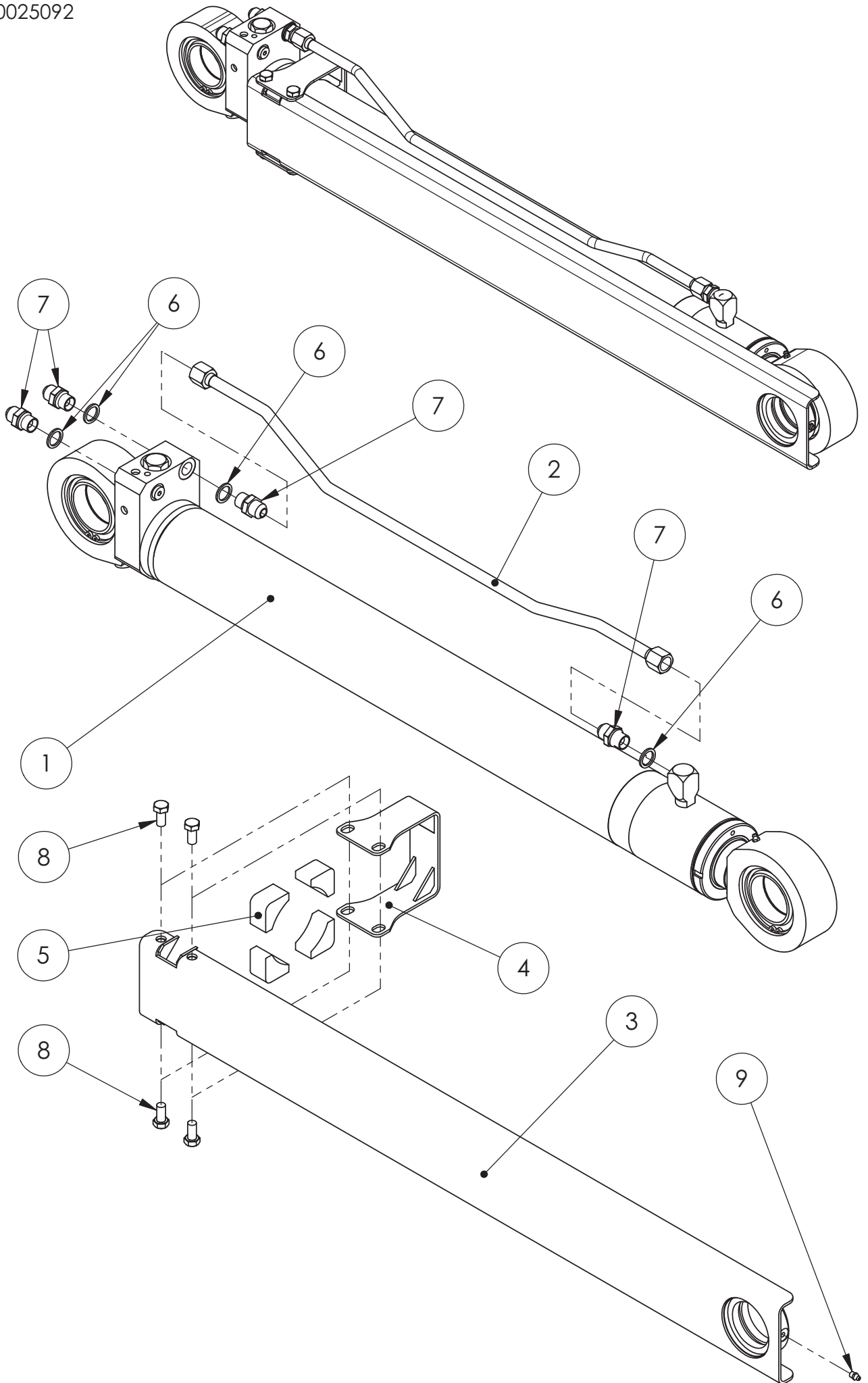

Item code	90025092	Revision	A
Title	CYLINDER	Date	16.11.2011
Specification	100/70X880 VAR		

Pos	Item code	Title	Specification	Pc	Nto Weight
1	28941001	CYLINDER	100/70X880	1	69.94
2	90025093	HYDRAULIC PIPE	L=935 KOK	1	0.79
3	90021152	COVER	HITS+KON	1	8.01
4	90021156	FASTENER	HITS	1	0.8
5	90023630	GLIDE PAD	12.5/45X30	4	0.04
6	3110042	USIT-SEAL	R-08 R 1/2"	4	0.01
7	3090917	CONNECTOR (STRAIGHT)	26-040010810 R 1/2" -7/8"JIC	4	0.11
8	3010442	HEW SCREW	M12X25 8.8 ZN DIN 933	4	0
9	3050003	GREASE NIPPLE	M8X1,25 DIN 71412	1	0

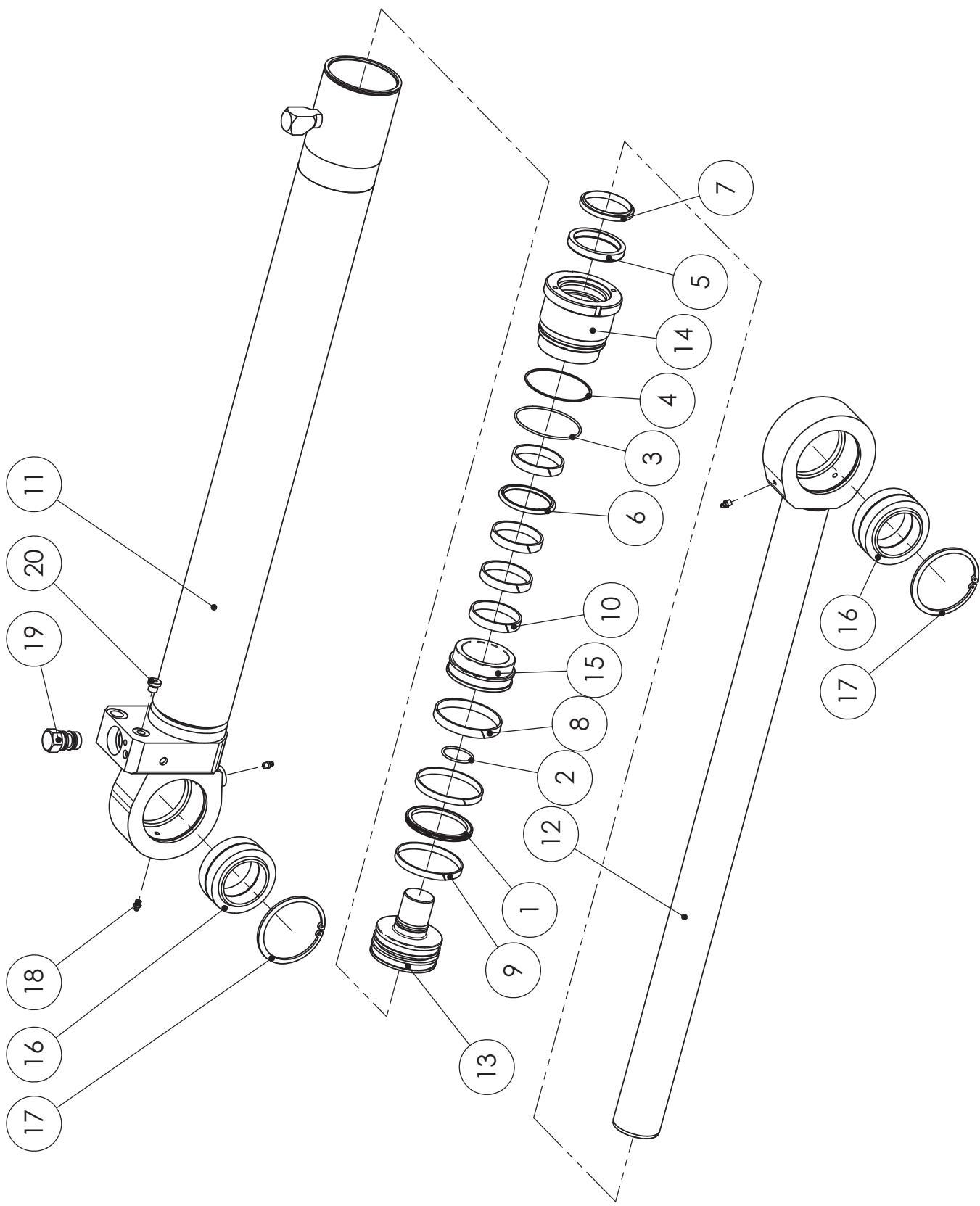

28891001 SYLINTERI

VARAOSAT \ RESERVDLAR \ SPARE PARTS \ ERSATZTEIL



## SPARE PART LIST

Item code	28891001	Revision	-
Title	SYLINTERI	Date	20.11.2012
Specification	100/70X880		

Pos	Item code	Title	Specification	Dimensions	Pc	Amount	Unit	Nto Weight
1	3110821	MÄNNÄNTIIVISTE KOLV TÄTNIING PISTON SEAL KOLBENDICHTUNG	300 100/84.5X6.3		1			0.1
2	3110258	O-RENGAS O-RING O-RING O-RING	42.2X3 90 SHORE		1			0.01
3	3110071	O-RENGAS O-RING O-RING O-RING	94.5X3 90 SHORE		1			0.02
4	3110614	TUKIRENGAS STÖDRING SUPPORTING RING STÜTZRING	TR 95/100X1.3		1			0
5	3110195	VARRENTIIVISTE KOLVSTÄNGSTÄTNIING ROD SEAL DICHTUNG FÜR KOLBENSTANGE	70/85X11.4		1			0.13
6	3110197	VARRENTIIVISTE KOLVSTÄNGSTÄTNIING ROD SEAL DICHTUNG FÜR KOLBENSTANGE	OMS-MR 70/85.1X6		1			0.07
7	3110196	LUOVUJIN AYSTRYKARE WIPER SEAL ABSTREIFER	GA 70/80X7/10		1			0.07
8	3110072	MÄNNÄNOHJAIN KOLV STYRNIING PISTON GUIDE KOLBENFÜHRUNG	E/PWR 100/94X13		1			0.09
9	3110843	MÄNNÄNOHJAIN KOLV STYRNIING PISTON GUIDE KOLBENFÜHRUNG	100/95X9.7		2			0.06
10	3110733	OHJAIN STYRNIING GUIDANCE STEUERUNG	I/PWR 70/76X13		4			0.07
11	28882101	SYLINTERIPIUTKI CYLINDER RÖR CYLINDER BARREL ZYLINDERROHR	100/70X880		1			33.48
12	28891204	MÄNNÄNVARSI KOLVSTÄNG PISTON ROD KOLBENSTANGE	70		1			26.56
13	28891201	MÄNTÄ KOLV PISTON KOLBEN	100	L=106	1			2.71
14	28852202	OHJAIN STYRNIING GUIDANCE STEUERUNG	100/70 2-TIIV.	L=103	1			2.8
15	28657105	HOLKKI HYLSA SLEEVE ACHSHALTER	ISKUN RAJOITIN HOLKKI	L=43	1			0.98
16	3100134	NIVELLAAKERI LEDLAGER JOINT BEARING GELENKLAGER	INA GE 70 ES		2			1.6
17	3060030	PIDÄTINRENGAS LÄSRING SNAP RING SPRENGRING	105X4 DIN 472		2			0
18	3050003	RASVANIPPA SMÖRJNIPPEL GREASE NIPPLE SCHMIERNIPPEL	M8X1.25 DIN 71412		4			0
19	28836108	TULPPA PLUGG PLUG DECKEL		L=55	1			0.23
20	3090211	TULPPA PLUGG PLUG DECKEL			1			0.02
-10	3111008	TIIVISTESARJA TÄTNIINGSSATS SEAL KIT DICHTUNGSSATZ	100/70		1			

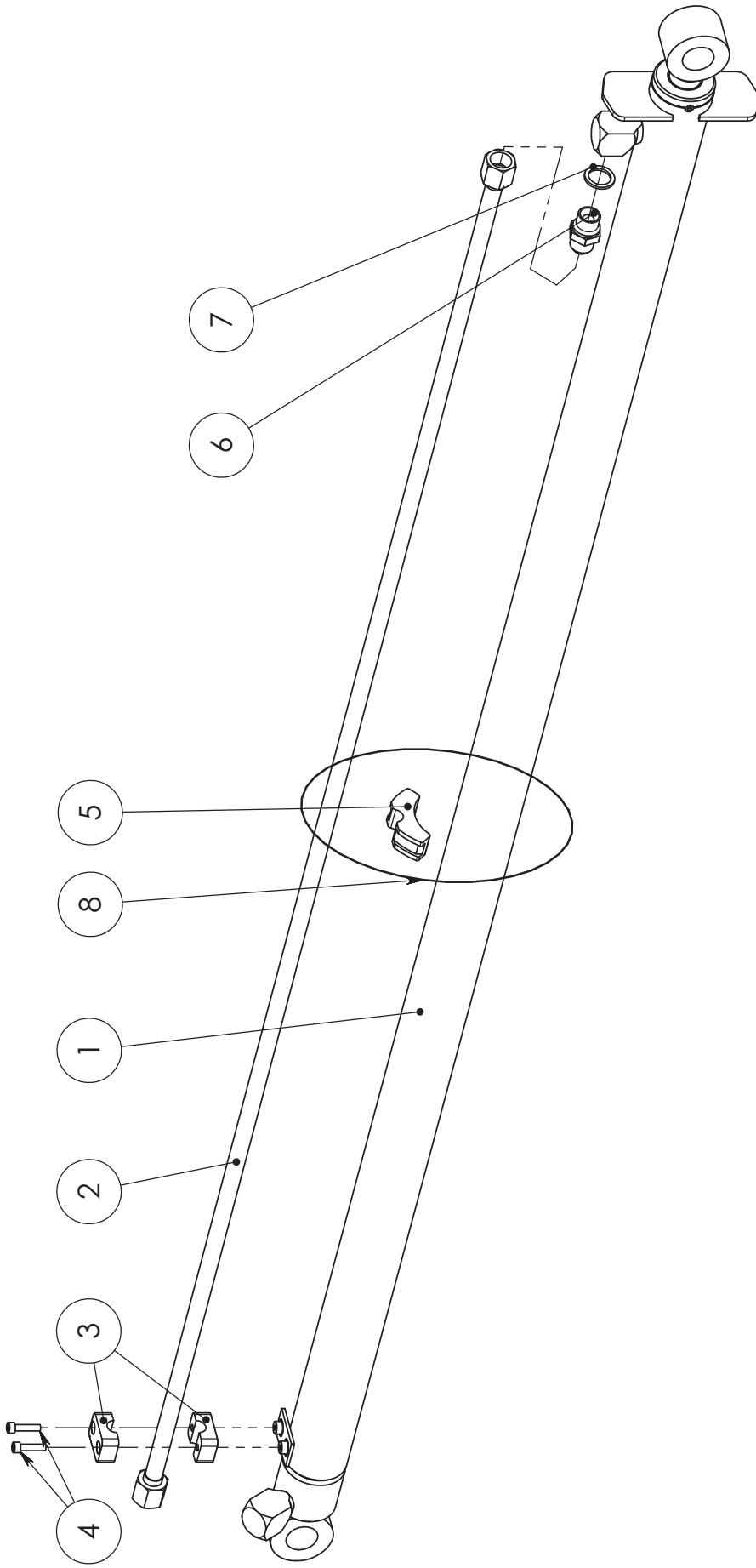

90021354 SYLINTERI

VARAOSAT \ RESERVDELAR \ SPARE PARTS \ ERSATZTEIL

Item code	90021354	Revision	A
Title	CYLINDER	Date	14.09.2006
Specification	50/30 X 1650		

Pos	Item code	Title	Specification	Pc	Nto Weight
1	28791001	CYLINDER	50/30X1650	1	27
2	90025971	PIPE	JATK.SYL. 50/30 X 1650	1	1.35
3	3090291	FASTENER		2	0.11
4	3010288	ALLEN SCREW	M6X25 8.8 ZN DIN 912	2	0
5	3090928	FASTENER		1	0.22
6	3090917	CONNECTOR (STRAIGHT)	26-040010810 R 1/2" -7/8"JIC	1	0.11
7	3110042	USIT-SEAL	R-08 R 1/2"	1	0.01
8	3090929	TENSIONER		1	

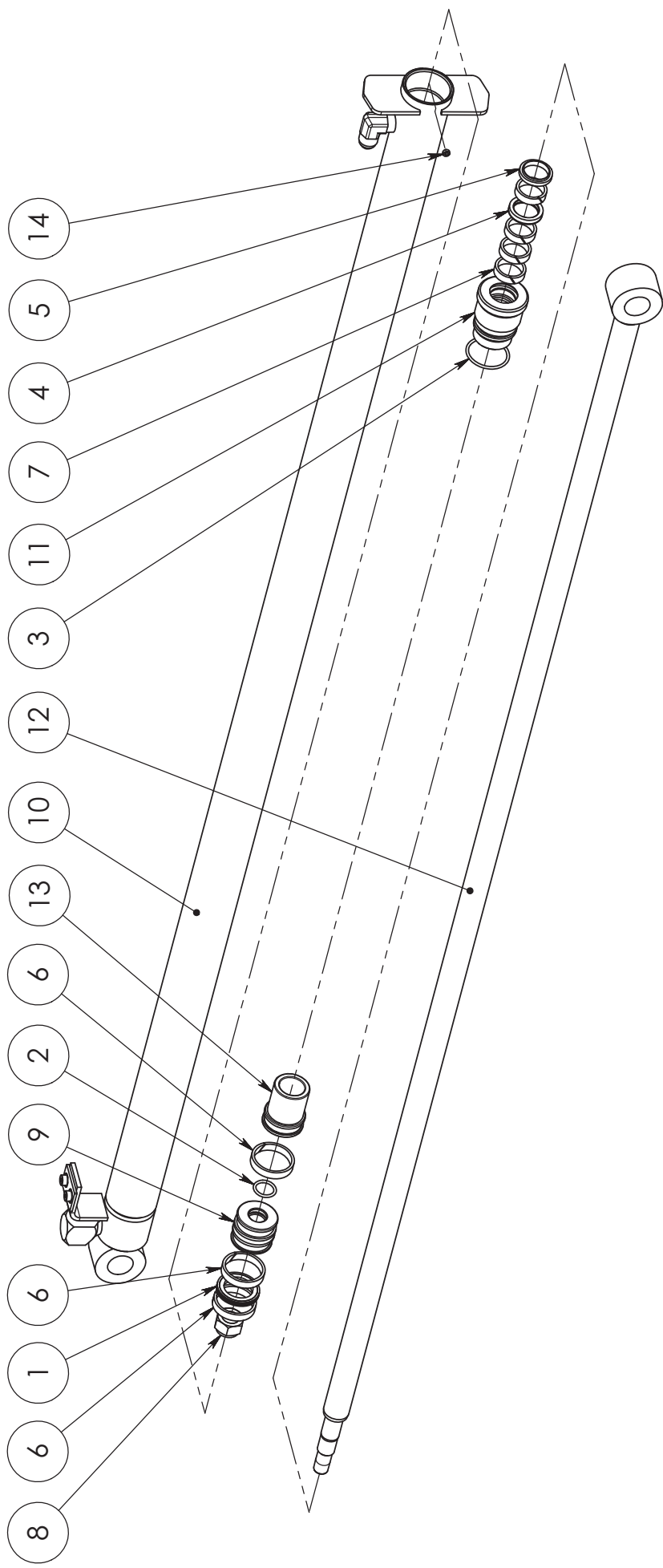

28791001 SYLINTERI





## SPARE PART LIST

Item code	28791001	Revision	-
Title	CYLINDER	Date	12.10.2006
Specification	50/30X1650		

Pos	Item code	Title	Specification	Pc	Nto Weight
1	3110676	PISTON SEAL	300 50/34.5X6	1	0.05
2	3110261	O-RING	21.2X3 90 SHORE	1	0
3	3110669	O-RING	45X3 90 SHORE	1	0.01
4	3110030	ROD SEAL	T22 30/40X7.3	1	0.02
5	3110027	WIPER SEAL	PW 30	1	0.02
6	3110677	PISTON GUIDE	E/PWR 50/44X10	3	0.03
7	3110741	GUIDANCE	I/PWR 30/36X10	4	0.02
8	3020009	NUT	M20 ZN DIN 985	1	0.07
9	28528201	PISTON	50 (SIMKO)	1	0.35
10	28791101	CYLINDER BARREL	50/30-1650	1	14.63
11	28586202	GUIDANCE	50/30	1	0.61
12	28791204	PISTON ROD	50/30-1650	1	10.78
13	28586105	SLEEVE	ISKURAJOTTINHOLKKI	1	0.37
14	3010793	ALLEN SCREW	M8X6 ZN DIN 914	1	0
1-7	3110756	SEAL KIT	50/30 F2010	1	

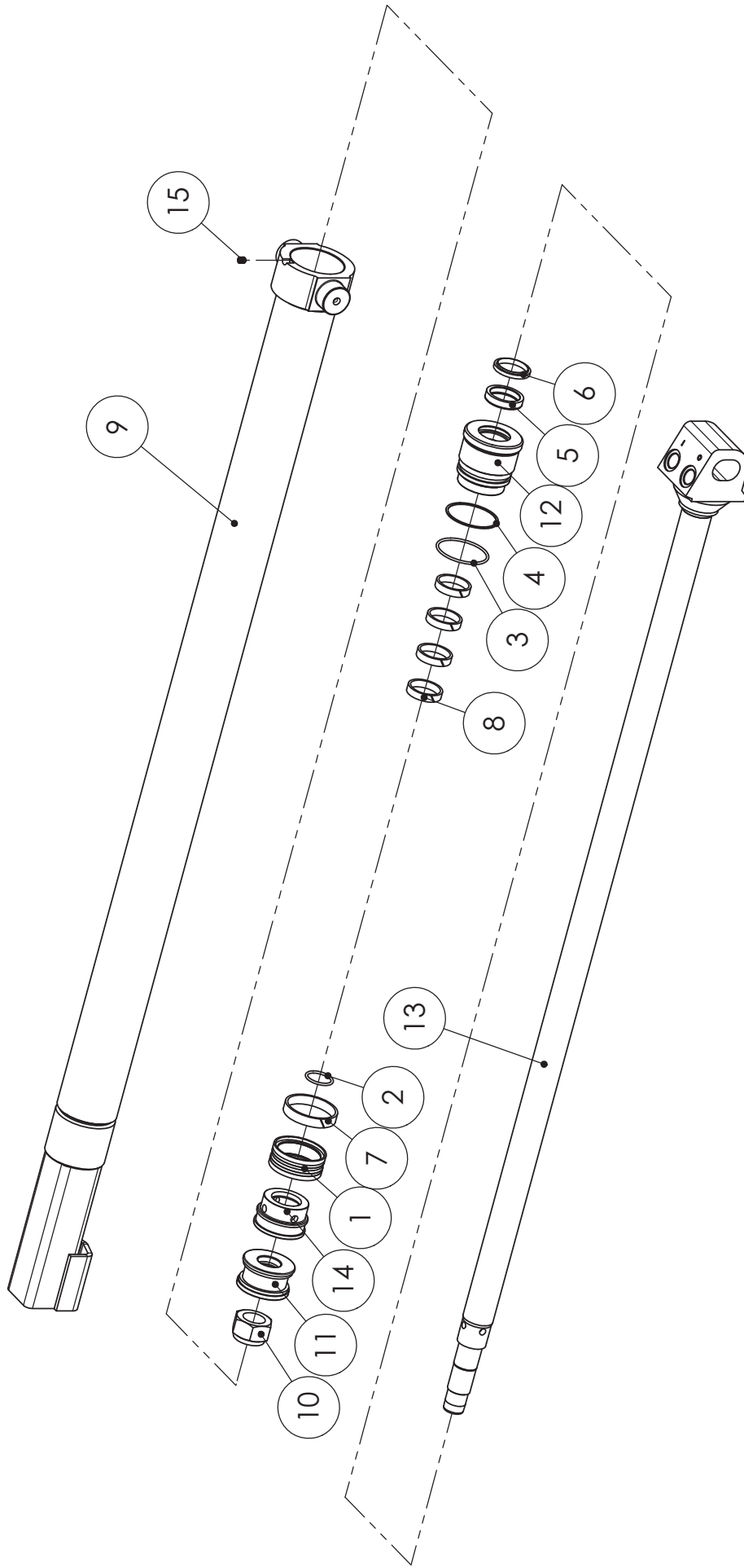



## SPARE PART LIST

Item code	28892001	Revision	-
Title	JATKESYLINTERI	Date	17.12.2012
Specification	70/40X1100		

Pos	Item code	Title	Specification	Dimensions	Pc	Amount	Unit	Nto Weight
1	3110317	MÄNNÄNTIIVISTE KOLV TÄTNIING PISTON SEAL KOLBENDICHTUNG	PDO 70/58X20		1			0.21
2	3110248	O-RENGAS O-RING O-RING O-RING	31.5X3 90 SHORE		1			0.01
3	3110009	O-RENGAS O-RING O-RING O-RING	64.5X3 90 SHORE		1			0.01
4	3110557	TUKIRENGAS STÖDRING SUPPORTING RING STÜTZRING	70/65X1.3 PU		1			0
5	3110010	VARRENTIIVISTE KOLVSTÄNGSTÄTNIING ROD SEAL DICHTUNG FÜR KOLBENSTANGE	NI 300 40/50X10		1			0.05
6	3110011	LUOVUJTIIN AYSTRYKARE WIPER SEAL ABSTREIFER	PW 40		1			0.03
7	3110697	MÄNNÄNOHJAIN KOLV STYRNIING PISTON GUIDE KOLBENFÜHRUNG	E/PWR 70/64X13		1			0.06
8	3110735	OHJAIN STYRNIING GUIDANCE STEUERUNG	I/PWR 40/46X10		4			0.03
9	28892101	SYLINTERIPUTKI CYLINDER BARREL ZYLINDERROHR	70/40X1100		1			16.82
10	3020145	MUTTERI MUTTER NUT MUTTER	M30X2 ZN DIN 980 V		1			0.24
11	28349201	MÄNTÄ KOLV PISTON KOLBEN	D=70 (PDO-TIIV.)	L=43	1			0.64
12	28581202	OHJAIN STYRNIING GUIDANCE STEUERUNG	70/40	L=72	1			1.38
13	28892204	MÄNNÄNVARSI KOLVSTÄNG PISTON ROD KOLBENSTANGE	70/40X1100		1			13.69
14	28581105	HOLKKI HYLSA SLEEVE ACHSHALTER	ISKURAJOITIN L=42	L=44	1			0.52
15	3010175	KUUSIOKOLORUUVI INSEKSKRUV ALLEN SCREW INNENSECHSKANTSCHRAUBE	M8X10 ZN DIN 914		1			0
1-8	3110736	TIIVISTESARJA TÄTNIINGSSATS SEAL KIT DICHTUNGSSATZ	70/40		1			0.49

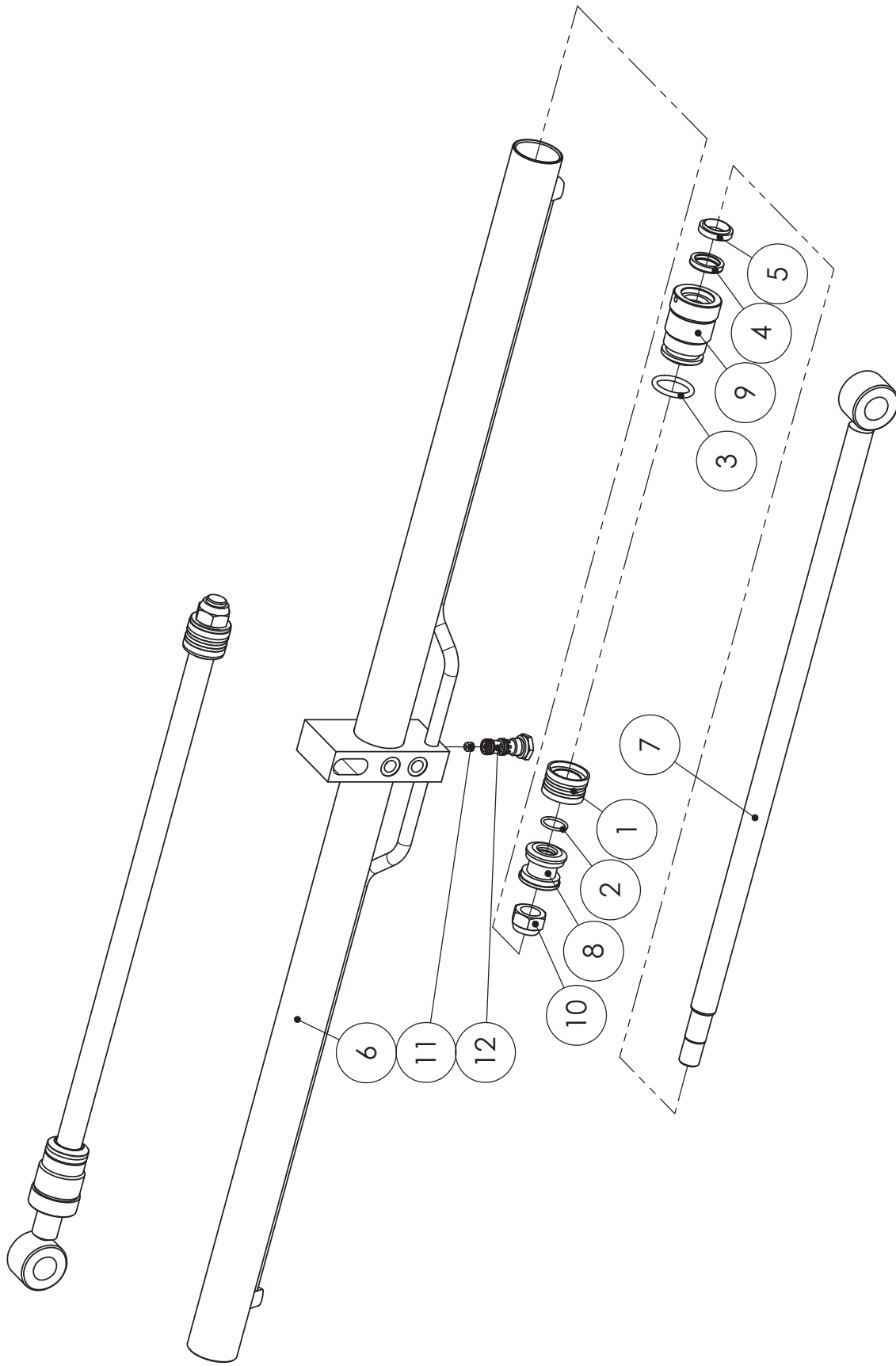

28864001 LEVITYSSYLINTERI

VARAOSAT \ RESERVDELAR \ SPARE PARTS \ ERSATZTEIL



## SPARE PART LIST

Item code	28864001	Revision	-
Title	LEVITYSSYLINTERI	Date	17.12.2012
Specification	50/30X2X650		

Pos	Item code	Title	Specification	Dimensions	Pc	Amount	Unit	Ntto Weight
1	3110013	MÄNNÄNTIIVISTE KOLV TÄTNING PISTON SEAL KOLBENDICHTUNG	DAS 50/34X18		2			0.18
2	3110003	O-RENGAS O-RING O-RING O-RING	26.2X3 70 SHORE		2			0.01
3	3110288	O-RENGAS O-RING O-RING O-RING	39.2X5.7 90 SHORE		2			0.03
4	3110030	VARRENTIIVISTE KOLVSTÄNGSTÄTNING ROD SEAL DICHTUNG FÜR KOLBENSTANGE	T22 30/40X7.3		2			0.02
5	3110313	LUOVUTIN AVSTRYKARE WIPER SEAL ABSTREIFER	GA 30/40X7/10		2			0.03
6	28864101	SYLINTERIPUTKI CYLINDER BARREL ZYLINDERROHR	50/30X2X650		1			14.3
7	28772204	MÄNNÄNVARSI KOLVSTÄNG PISTON ROD KOLBENSTANGE	50/30 X 2 X 650		2			5.2
8	28337201	MÄNTÄ KOLV PISTON KOLBEN	D=50 DBM	L=43	2			0.26
9	28337202	OHJAIN STYRNING GUIDANCE STEUERUNG	50/30	L=82	2			0.82
10	3020026	MUTTERI MUTTER NUT MUTTER	M24 ZN DIN 985		2			0.11
11	21510225	KURISTIN STRYP RESTRICTOR DROSSEL	M10X10/D=1.0		1			0
12	3120843	VENTTIILI VENTIL VALVE VENTIL			1			0.13
1-5	3110324	TIIVISTESARJA TÄTNINGSSATS SEAL KIT DICHTUNGSSATZ	50/30		1			

90025869

100/80x500 LEFT ( ADJUSTABLE FOOT )

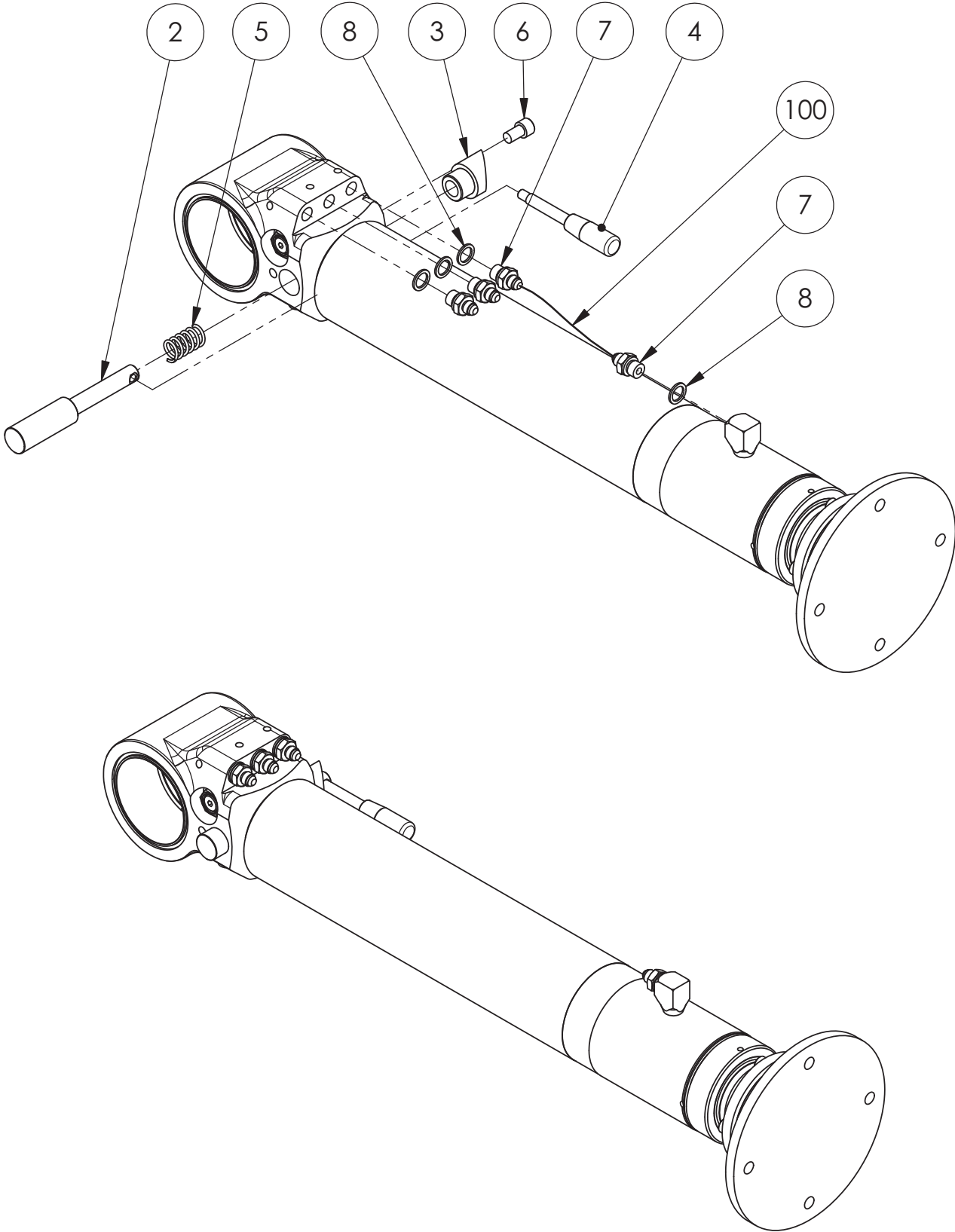

Item code	90025869	Revision	-
Title	STABILIZER	Date	13.11.2012
Specification	100/80X500 LEFT ( ADJUSTABLE FOOT )		

Pos	Item code	Title	Specification	Pc	Nto Weight
1	28933001	CYLINDER	100/80X500	1	64.79
2	90025017	SPINDLE	30/18-179	1	0.63
3	90025018	SLEEVE		1	0.26
4	3301574	LEVER	GN 310-12-125-E-NI M10	1	0.03
5	3300533	SPRING	18/45/7.6/6.88 -1643 SF-TF3	1	0.02
6	3010604	ALLEN SCREW	M12X20 8.8 DIN 912	1	0
7	3090901	CONNECTOR	6010-06-06	4	0.05
8	3110040	USIT-SEAL	R-06 R 3/8"	4	0
100	3133257	HYDRAULIC HOSE	A50005-06-06/241T-06/A50005-06-06/L=570/TEX	1	

90025868  
100/80x500 RIGHT ( ADJUSTABLE FOOT )

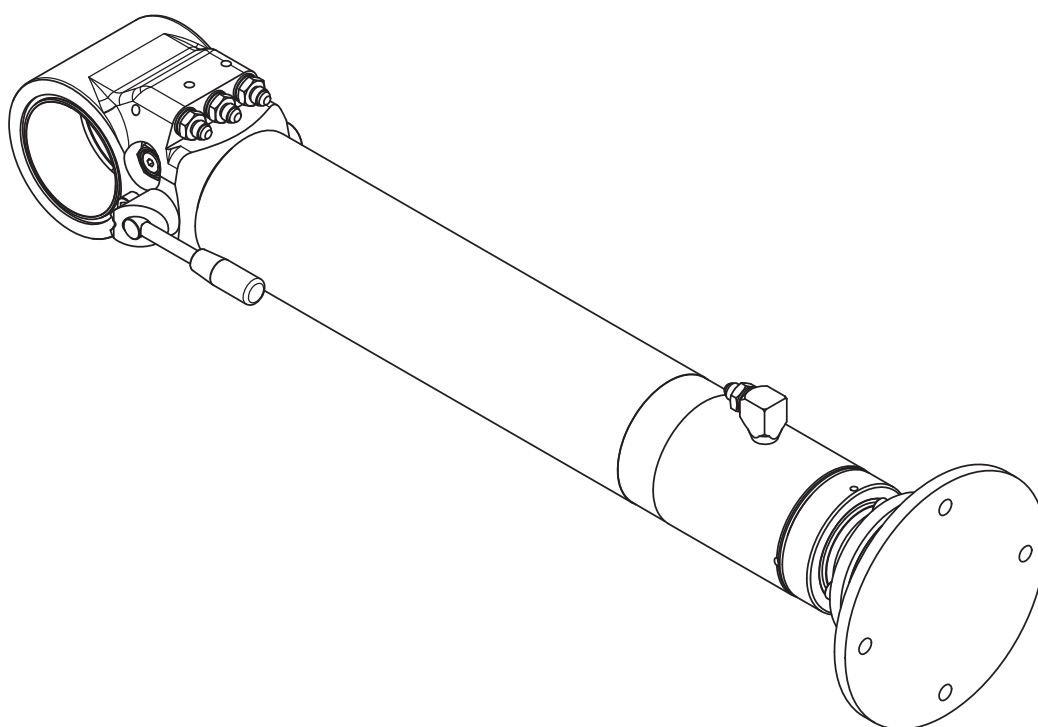
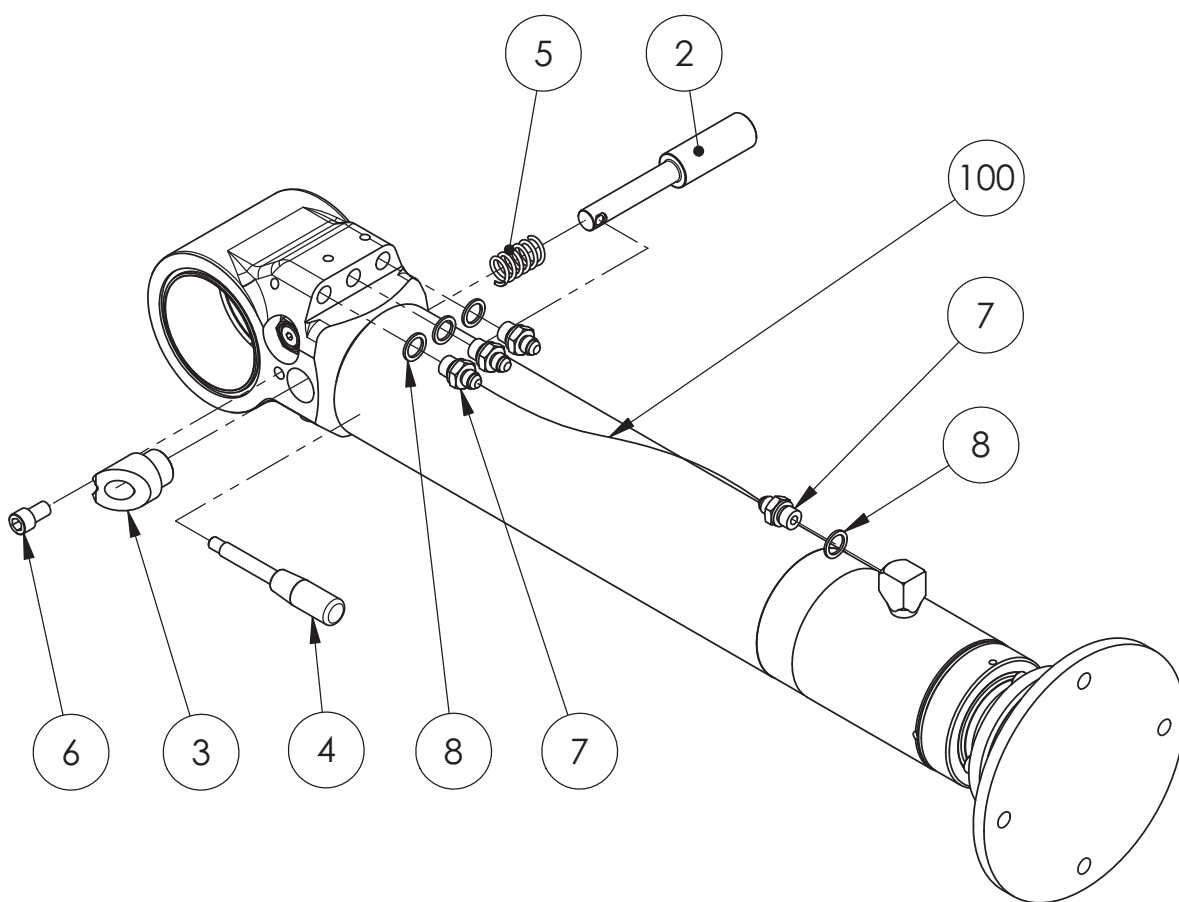



Item code	90025868	Revision	-
Title	STABILIZER	Date	13.11.2012
Specification	100/80X500 RIGHT ( ADJUSTABLE FOOT )		

Pos	Item code	Title	Specification	Pc	Nto Weight
1	28933001	CYLINDER	100/80X500	1	64.79
2	90025017	SPINDLE	30/18-179	1	0.63
3	90025018	SLEEVE		1	0.26
4	3301574	LEVER	GN 310-12-125-E-NI M10	1	0.03
5	3300533	SPRING	18/45/7.6/6.88 -1643 SF-TF3	1	0.02
6	3010604	ALLEN SCREW	M12X20 8.8 DIN 912	1	0
7	3090901	CONNECTOR	6010-06-06	4	0.05
8	3110040	USIT-SEAL	R-06 R 3/8"	4	0
100	3133257	HYDRAULIC HOSE	A50005-06-06/241T-06/A50005-06-06/L=570/TEX	1	

# 28933001 SYLINTERI

VARAOSAT \ RESERVDELAR \ SPARE PARTS \ ERSATZTEIL

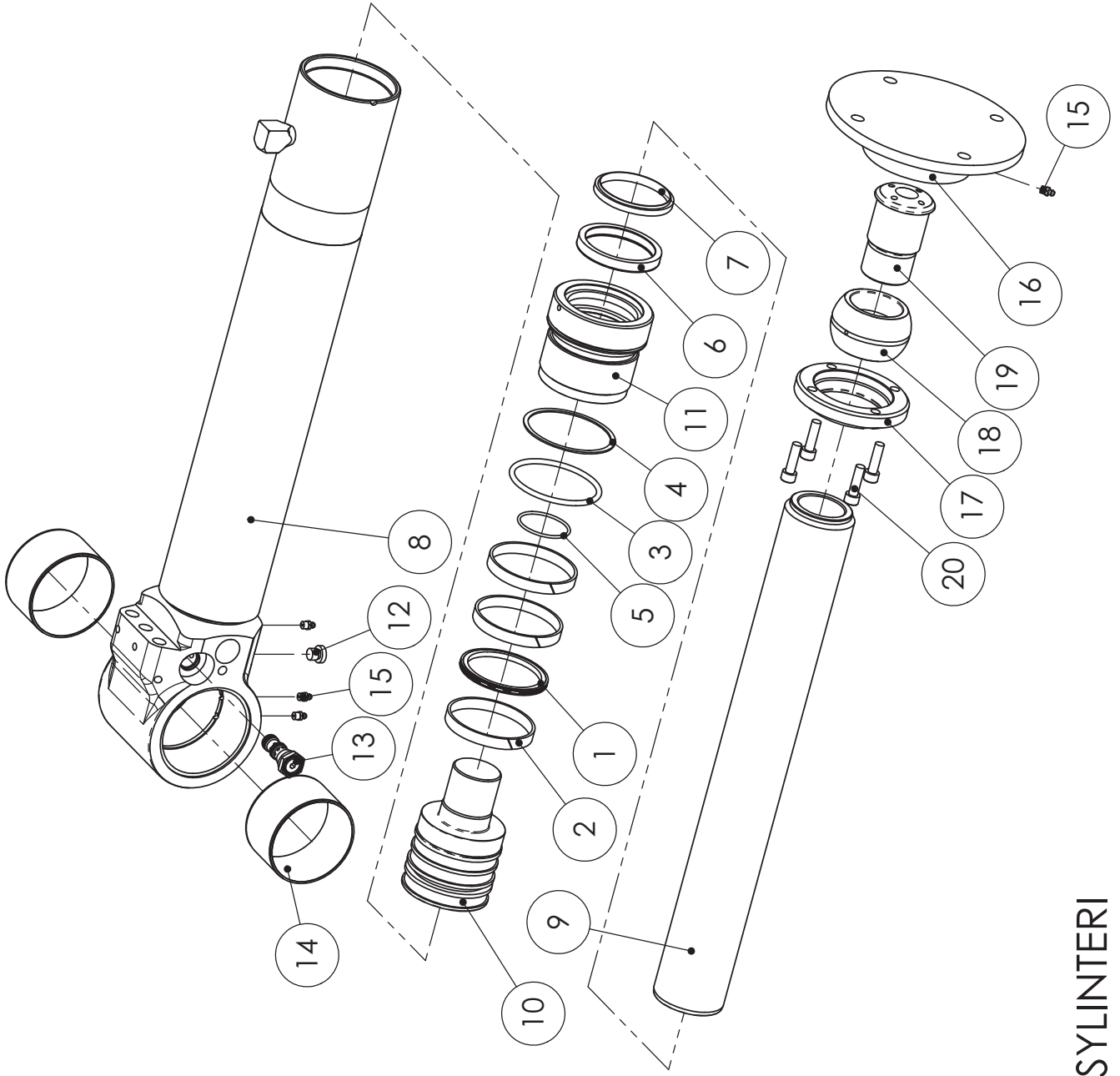



## SPARE PART LIST

Item code	28933001	Revision	-
Title	CYLINDER	Date	16.10.2012
Specification	100/80X500		

Pos	Item code	Title	Specification	Pc	Nto Weight
1	3110821	PISTON SEAL	300 100/84.5X6.3	1	0.1
2	3110072	PISTON GUIDE	E/PWR 100/94X13	3	0.09
3	3111009	O-RING	94.1X5.7 90 SHORE	1	0.01
4	3111010	SUPPORTING RING	95/105X1.7 PU	1	0
5	3110029	O-RING	54.5X3 90 SHORE	1	0.01
6	3110251	ROD SEAL	NI 300 80/95X12	1	0.16
7	3110111	WIPER SEAL	GA 80/90X7/10	1	0.08
8	28932101	CYLINDER BARREL	100/80X500	1	30.93
9	28932302	PISTON ROD	80	1	14.53
10	28894201	PISTON	100	1	5.26
11	28894202	GUIDANCE	100/80	1	2.67
12	3090211	PLUG		1	0.02
13	3120843	VALVE		1	0.13
14	3100344	BUSHING		2	0.38
15	3050003	GREASE NIPPLE	WB 802 10060		
16	28861106	BASE	M8X1.25 DIN 71412	4	0
17	28861107	COVER		1	5.55
18	3100428	BEARING		1	1.07
19	28894401	AXLE	NIVELLAAKERIN PALLO GEF 60 ES	1	1.14
20	3010970	ALLEN SCREW	60/M55	1	2.1
1-7	3111011	SEAL KIT	M10X35 12.9 DIN 912	4	0
			100/80	1	

90025864  
100/80x500 RIGHT ( FIXED FOOT )

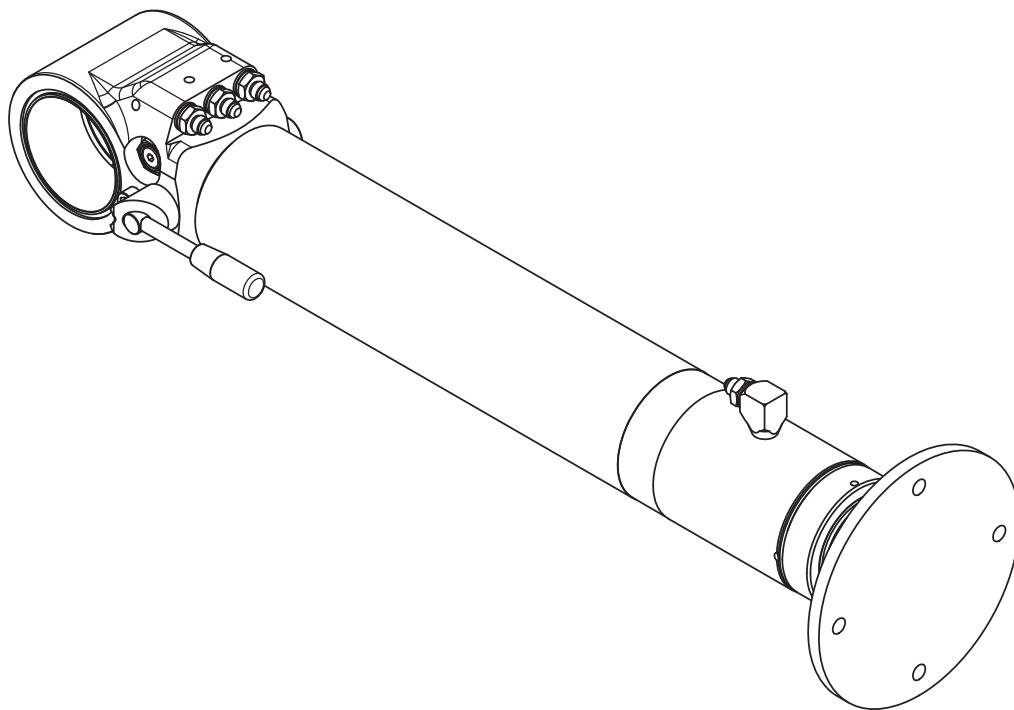
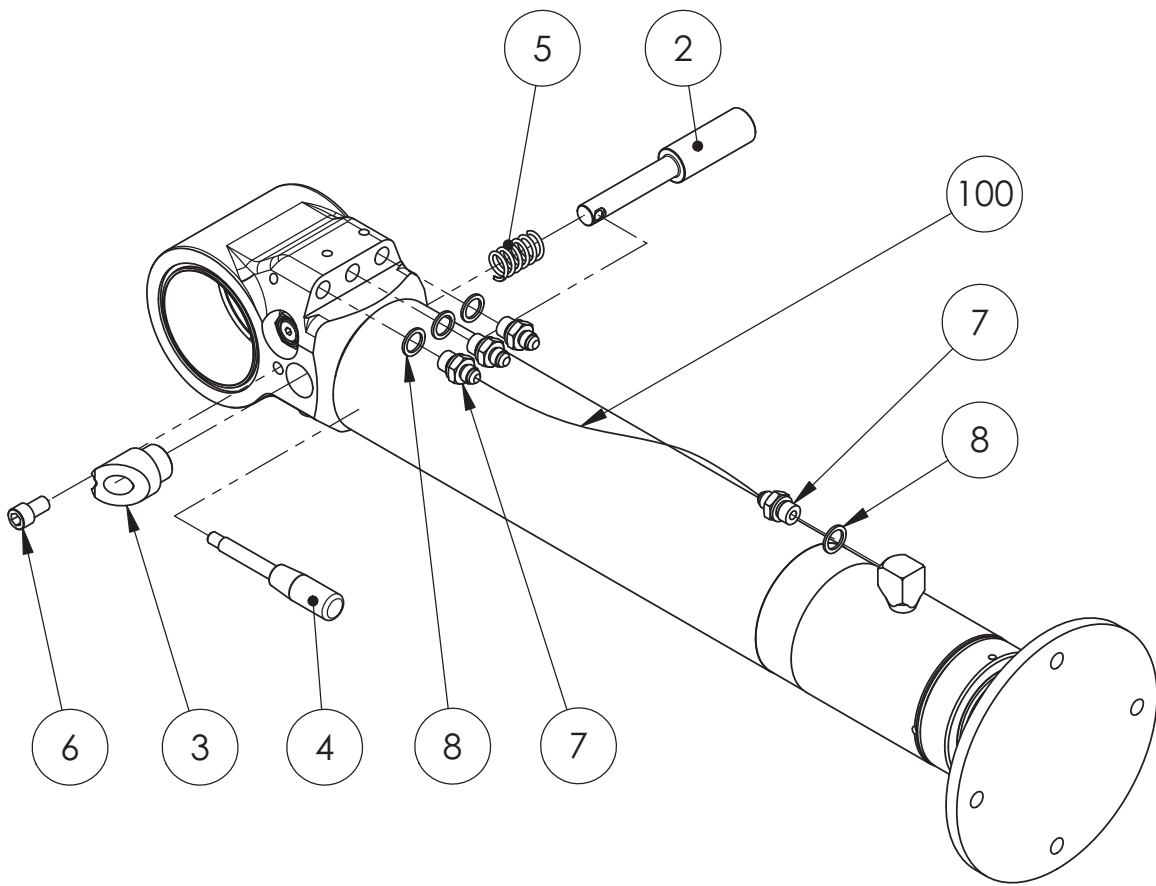

Item code	90025864	Revision	-
Title	STABILIZER	Date	13.11.2012
Specification	100/80X500 RIGHT ( FIXED FOOT )		

Pos	Item code	Title	Specification	Pc	Nto Weight
1	28932001	CYLINDER	100/80X500	1	61.2
2	90025017	SPINDLE	30/18-179	1	0.63
3	90025018	SLEEVE		1	0.26
4	3301574	LEVER	GN 310-12-125-E-NI M10	1	0.03
5	3300533	SPRING	18/45/7.6/6.88 -1643 SF-TF3	1	0.02
6	3010604	ALLEN SCREW	M12X20 8.8 DIN 912	1	0
7	3090901	CONNECTOR	6010-06-06	4	0.05
8	3110040	USIT-SEAL	R-06 R 3/8"	4	0
100	3133257	HYDRAULIC HOSE	A50005-06-06/241T-06/A50005-06-06/L=570/TEX	1	

90025865  
100/80x500 LEFT ( FIXED FOOT )

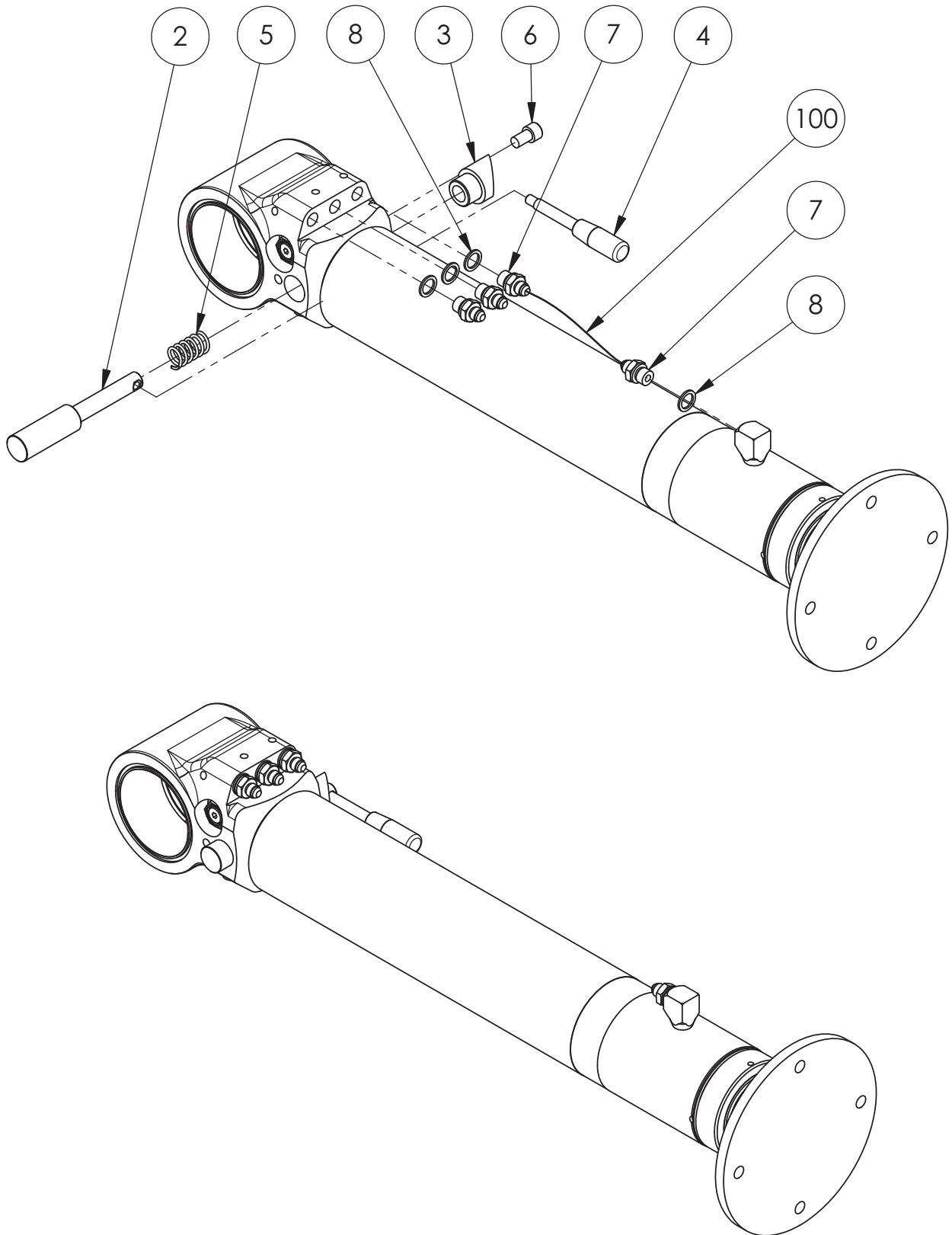

Item code	90025865	Revision	-
Title	STABILIZER	Date	13.11.2012
Specification	100/80X500 LEFT ( FIXED FOOT )		

Pos	Item code	Title	Specification	Pc	Nto Weight
1	28932001	CYLINDER	100/80X500	1	61.2
2	90025017	SPINDLE	30/18-179	1	0.63
3	90025018	SLEEVE		1	0.26
4	3301574	LEVER	GN 310-12-125-E-NI M10	1	0.03
5	3300533	SPRING	18/45/7.6/6.88 -1643 SF-TF3	1	0.02
6	3010604	ALLEN SCREW	M12X20 8.8 DIN 912	1	0
7	3090901	CONNECTOR	6010-06-06	4	0.05
8	3110040	USIT-SEAL	R-06 R 3/8"	4	0
100	3133257	HYDRAULIC HOSE	A50005-06-06/241T-06/A50005-06-06/L=570/TEX	1	

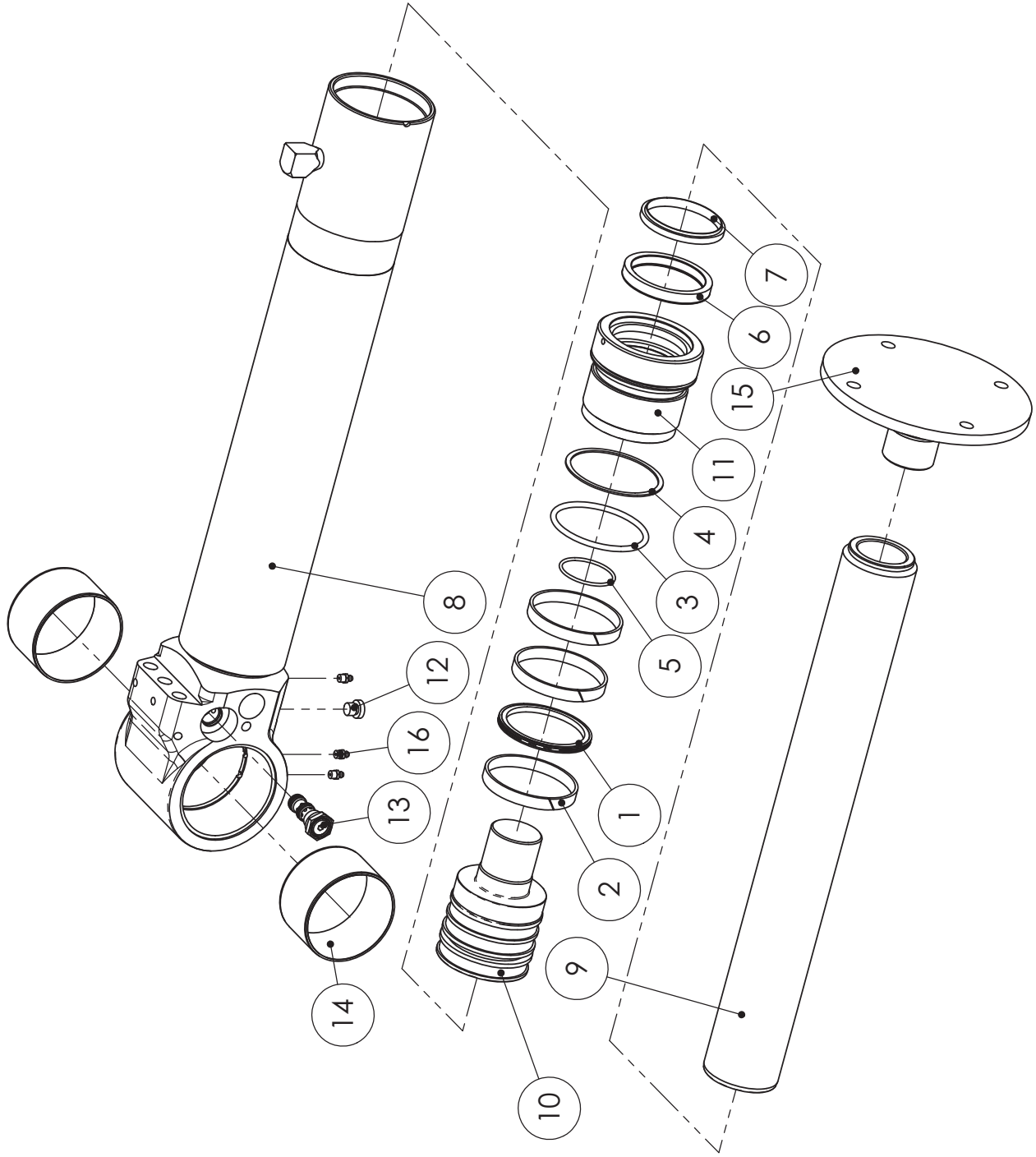

28932001 SYLINTERI

VARAOSAT \ RESERVDELAR \ SPARE PARTS \ ERSATZTEIL





## SPARE PART LIST

Item code	28932001	Revision	-
Title	CYLINDER	Date	16.10.2012
Specification	100/80X500		

Pos	Item code	Title	Specification	Pc	Nto Weight
1	3110821	PISTON SEAL	300 100/84.5X6.3	1	0.1
2	3110072	PISTON GUIDE	E/PWR 100/94X13	3	0.09
3	3111009	O-RING	94.1 X5.7 90 SHORE	1	0.01
4	3111010	SUPPORTING RING	95/105X1.7 PU	1	0
5	3110029	O-RING	54.5X3 90 SHORE	1	0.01
6	3110251	ROD SEAL	NI 300 80/95X12	1	0.16
7	3110111	WIPER SEAL	GA 80/90X7/10	1	0.08
8	28932101	CYLINDER BARREL	100/80X500	1	30.93
9	28932302	PISTON ROD	80	1	14.53
10	28894201	PISTON	100	1	5.26
11	28894202	GUIDANCE	100/80	1	2.67
12	3090211	PLUG		1	0.02
13	3120843	VALVE		1	0.13
14	3100344	BUSHING		2	0.38
15	28901106	BASE	WB 802 10060	1	6.27
16	3050003	GREASE NIPPLE	TUKIJALKA	1	6.27
1-7	3111011	SEAL KIT	M8X1,25 DIN 71412	3	0
			100/80	1	

90025345  
100/80x600 RIGHT ( ADJUSTABLE FOOT )

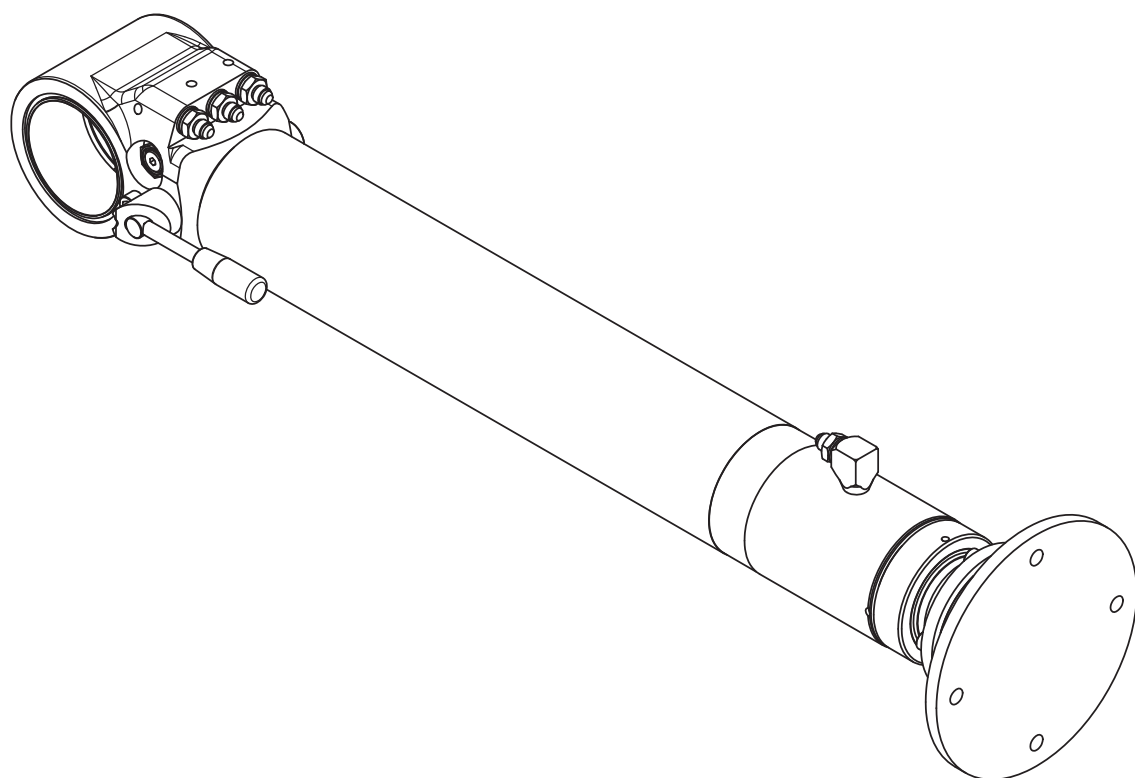
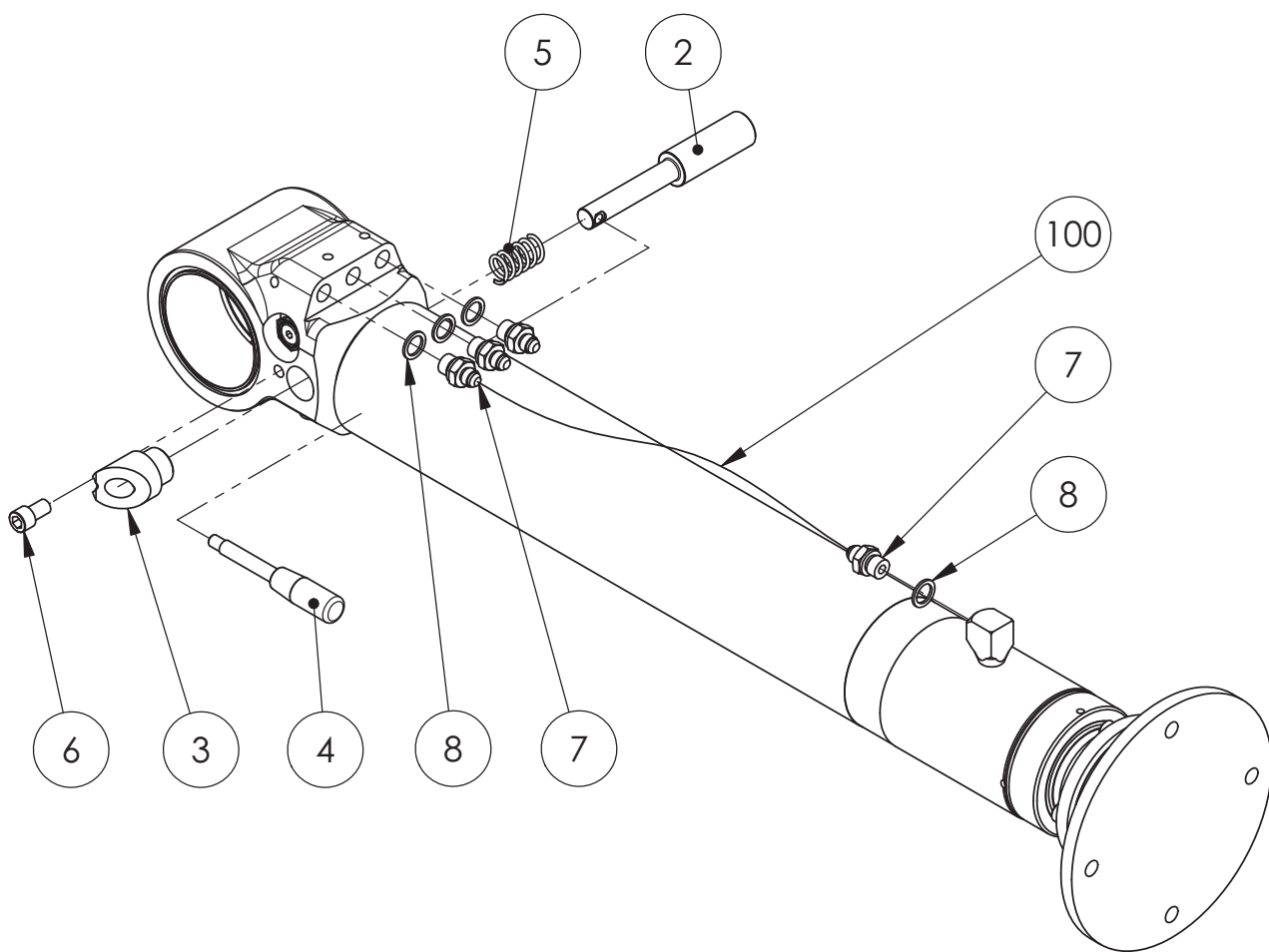

Item code	90025345	Revision	-
Title	STABILIZER	Date	08.02.2012
Specification	100/80X600 RIGHT ( ADJUSTABLE FOOT )		

Pos	Item code	Title	Specification	Pc	Nto Weight
1	28894001	CYLINDER	100/80X600	1	69.07
2	90025017	SPINDLE	30/18-179	1	0.63
3	90025018	SLEEVE		1	0.26
4	3301574	LEVER	GN 310-12-125-E-NI M10	1	0.03
5	3300533	SPRING	18/45/7.6/6.88 -1643 SF-TF3	1	0.02
6	3010604	ALLEN SCREW	M12X20 8.8 DIN 912	1	0
7	3090901	CONNECTOR	6010-06-06	4	0.05
8	3110040	USIT-SEAL	R-06 R 3/8"	4	0
100	3133057	HYDRAULIC HOSE	A50005-06-06/241T-06/A50005-06-06/L=670/TEX	1	

90025346

100/80x600 LEFT ( ADJUSTABLE FOOT )

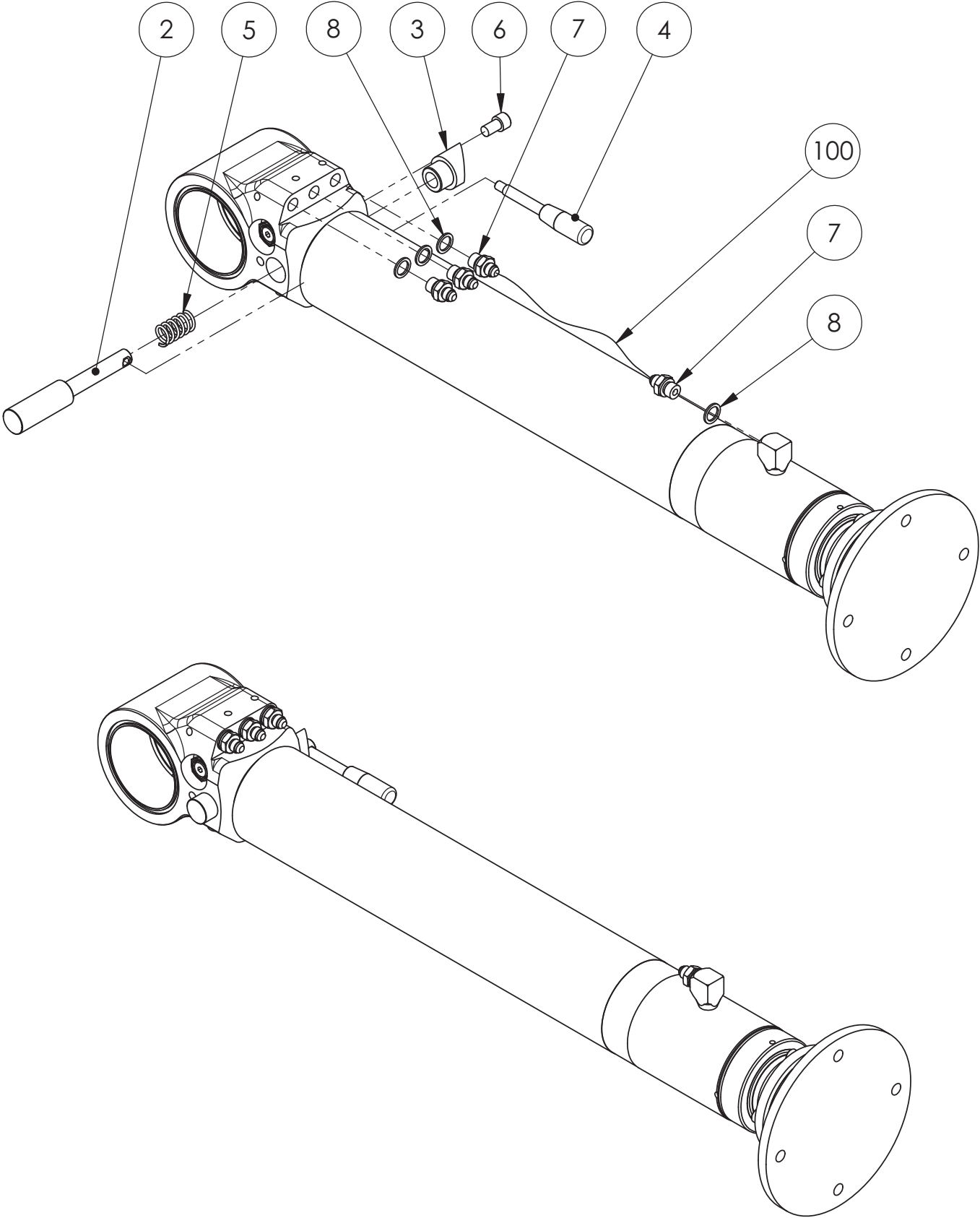

Item code	90025346	Revision	-
Title	STABILIZER	Date	08.02.2012
Specification	100/80X600 LEFT ( ADJUSTABLE FOOT )		

Pos	Item code	Title	Specification	Pc	Nto Weight
1	28894001	CYLINDER	100/80X600	1	69.07
2	90025017	SPINDLE	30/18-179	1	0.63
3	90025018	SLEEVE		1	0.26
4	3301574	LEVER	GN 310-12-125-E-NI M10	1	0.03
5	3300533	SPRING	18/45/7.6/6.88 -1643 SF-TF3	1	0.02
6	3010604	ALLEN SCREW	M12X20 8.8 DIN 912	1	0
7	3090901	CONNECTOR	6010-06-06	4	0.05
8	3110040	USIT-SEAL	R-06 R 3/8"	4	0
100	3133057	HYDRAULIC HOSE	A50005-06-06/241T-06/A50005-06-06/L=670/TEX	1	

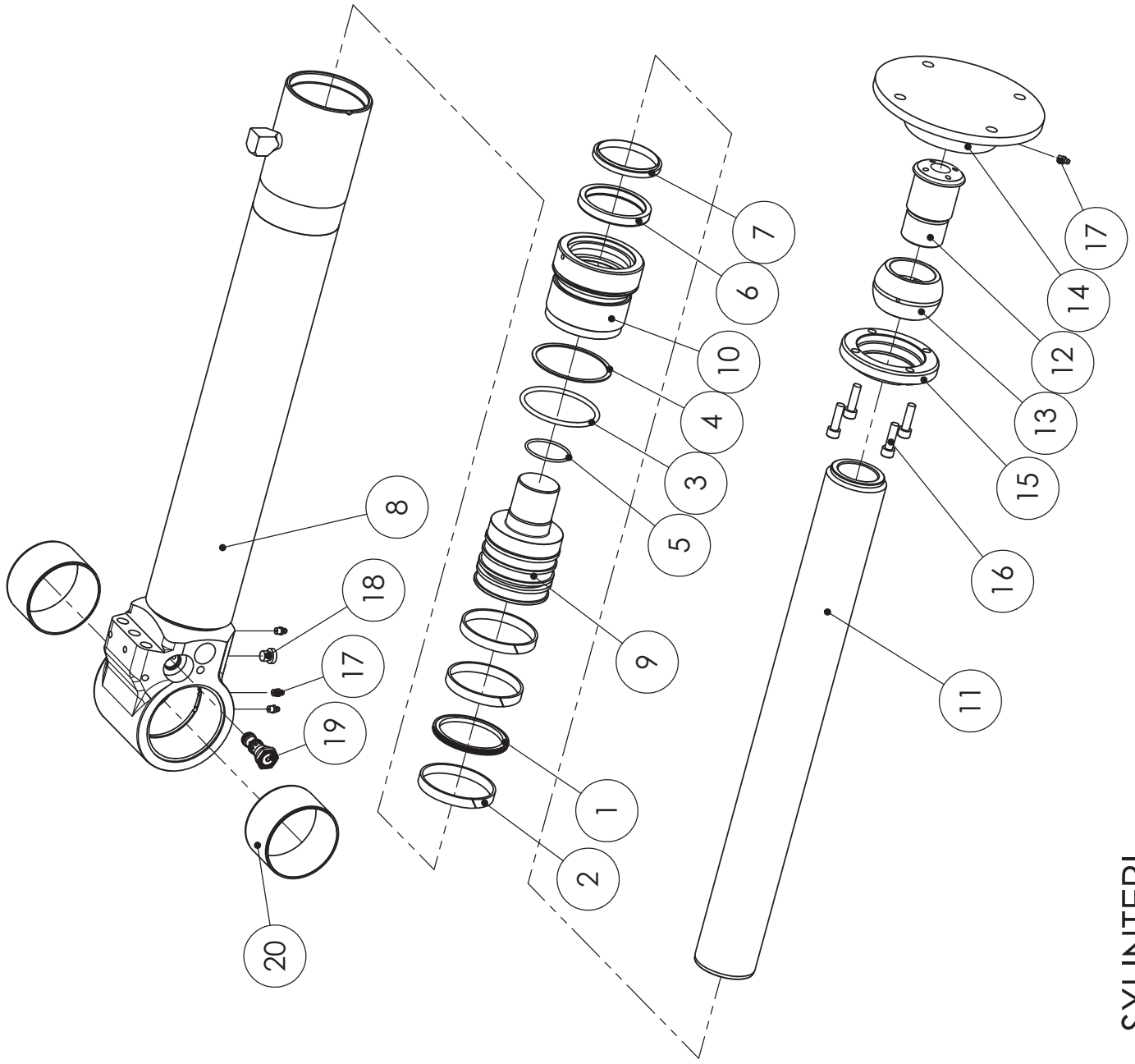

28894001 SYLINTERI

VARAOSAT \ RESERVDELAR \ SPARE PARTS \ ERSATZTEIL



## SPARE PART LIST

Item code	28894001	Revision	-
Title	CYLINDER	Date	29.08.2013
Specification	100/80X600		

Pos	Item code	Title	Specification	Pc	Nto Weight
1	3110821	PISTON SEAL	300 100/84.5X6.3	1	0.1
2	3110072	PISTON GUIDE	E/PWR 100/94X13	3	0.09
3	3111009	O-RING	94.1X5.7 90 SHORE	1	0.01
4	3111010	SUPPORTING RING	95/105X1.7 PU	1	0
5	3110029	O-RING	54.5X3 90 SHORE	1	0.01
6	3110251	ROD SEAL	NI 300 80/95X12	1	0.16
7	3110111	WIPER SEAL	GA 80/90X7/10	1	0.08
8	28894101	CYLINDER BARREL	100/80X600	1	32.92
9	28894201	PISTON	100	1	5.26
10	28894202	GUIDANCE	100/80	1	2.67
11	28894302	PISTON ROD	80	1	16.93
12	28894401	AXLE	60/M55	1	2.1
13	3100428	BEARING	NIVELAKERIN PALLO GEF 60 ES	1	1.14
14	28861106	BASE		1	5.55
15	28861107	COVER		1	1.07
16	3010970	ALLEN SCREW	M10X35 12.9 DIN 912	4	0
17	3050003	GREASE NIPPLE	M8X1.25 DIN 71412	4	0
18	3090211	PLUG		1	0.02
19	3120843	VALVE		1	0.13
20	3100344	BUSHING	WB 802 10060	2	0.38
1-7	3111011	SEAL KIT	100/80	1	

90025719  
100/80x600 RIGHT ( FIXED FOOT )

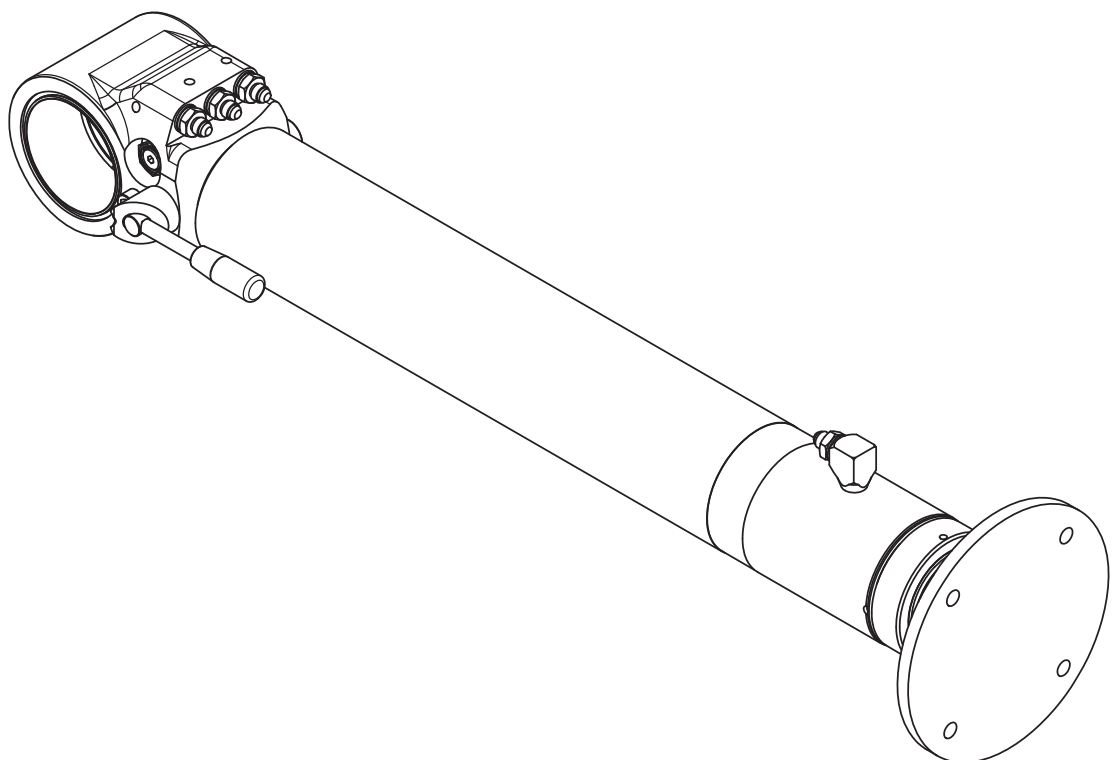
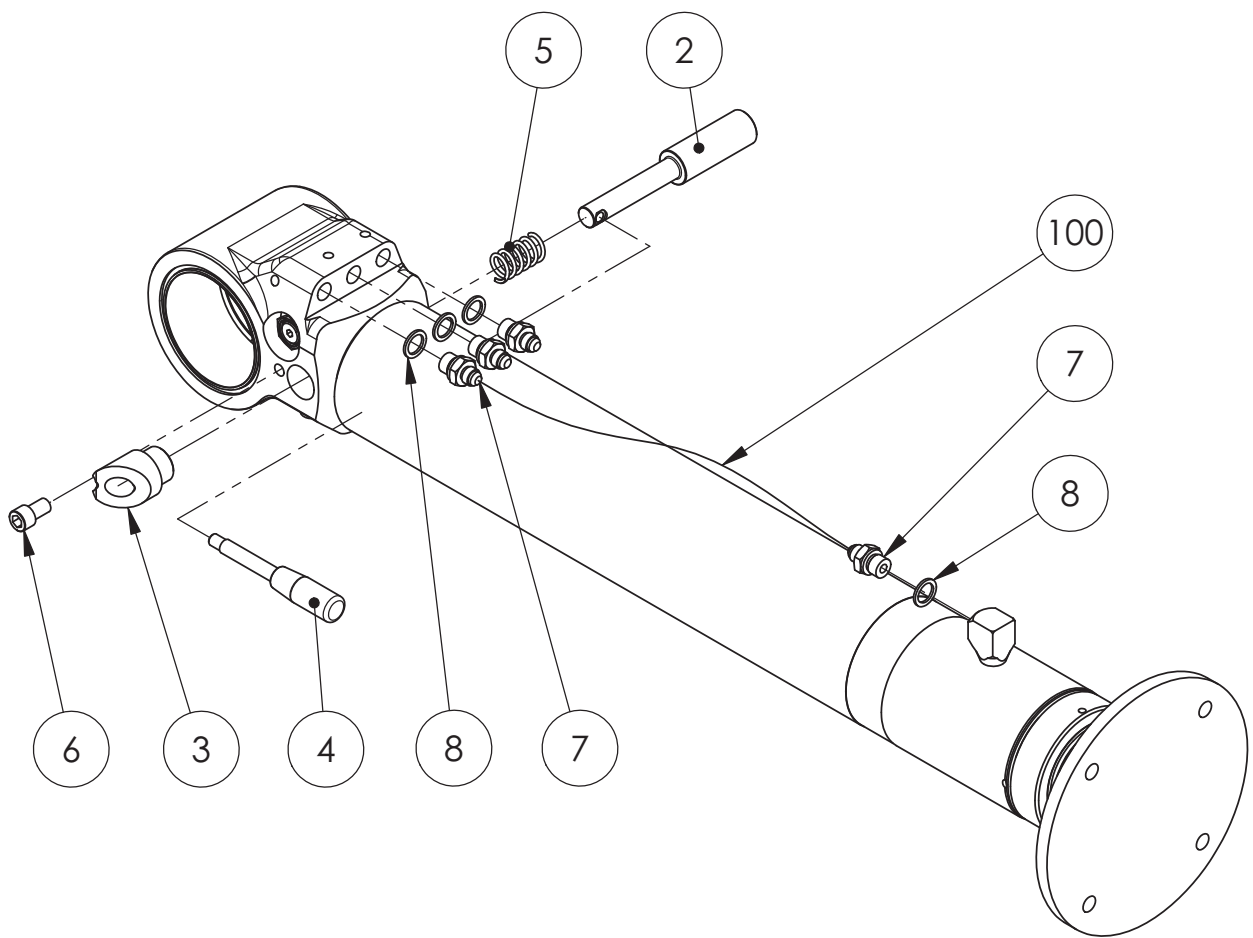



Item code	90025719	Revision	-
Title	STABILIZER	Date	06.09.2012
Specification	100/80X600 RIGHT ( FIXED FOOT )		

Pos	Item code	Title	Specification	Pc	Nto Weight
1	28901001	CYLINDER	100/80X600	1	65.59
2	90025017	SPINDLE	30/18-179	1	0.63
3	90025018	SLEEVE		1	0.26
4	3301574	LEVER	GN 310-12-125-E-NI M10	1	0.03
5	3300533	SPRING	18/45/7.6/6.88 -1643 SF-TF3	1	0.02
6	3010604	ALLEN SCREW	M12X20 8.8 DIN 912	1	0
7	3090901	CONNECTOR	6010-06-06	4	0.05
8	3110040	USIT-SEAL	R-06 R 3/8"	4	0
100	3133057	HYDRAULIC HOSE	A50005-06-06/241T-06/A50005-06-06/L=670/TEX	1	

90025720  
100/80x600 LEFT ( FIXED FOOT )

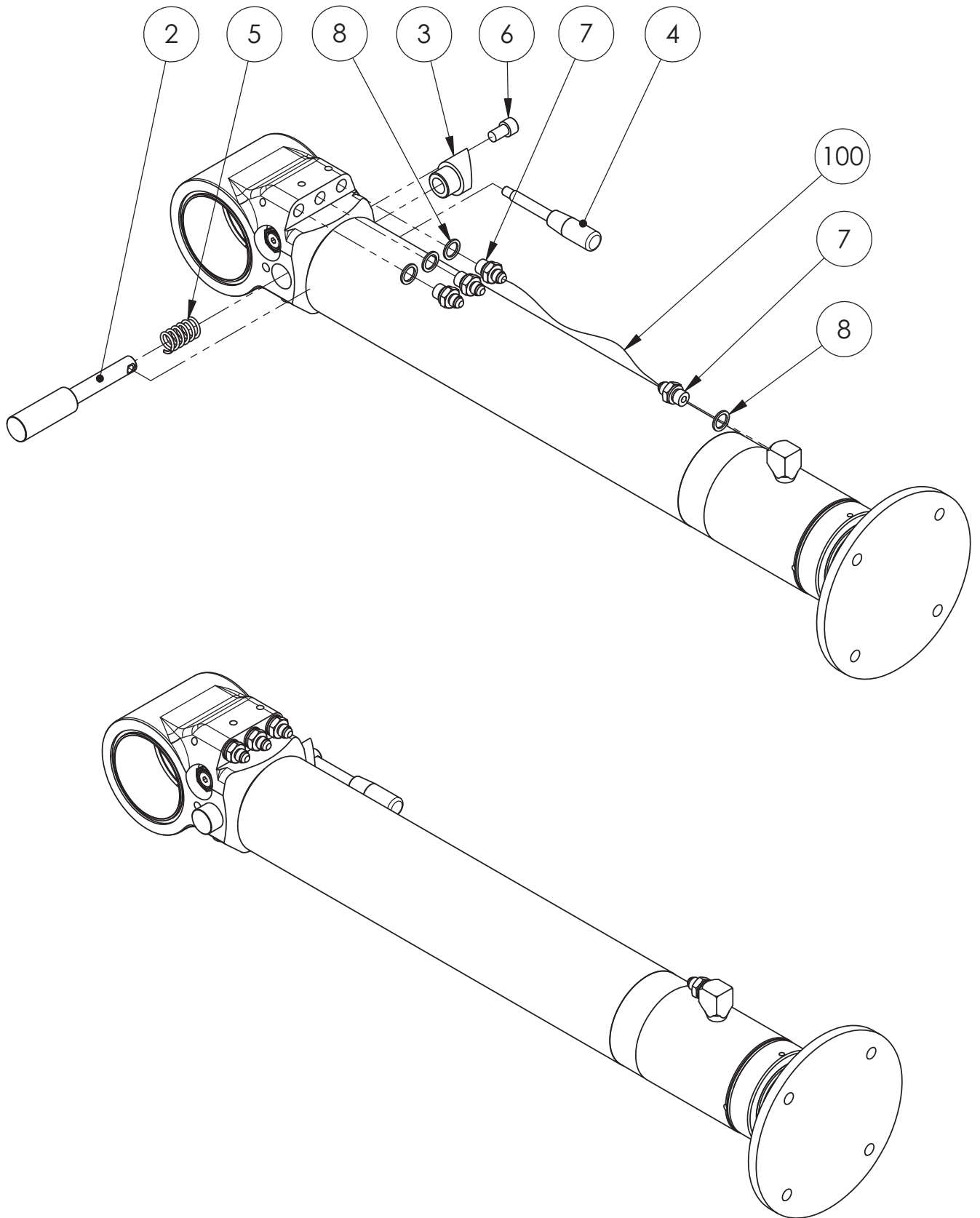

Item code	90025720	Revision	-
Title	STABILIZER	Date	06.09.2012
Specification	100/80X600 LEFT ( FIXED FOOT )		

Pos	Item code	Title	Specification	Pc	Nto Weight
1	28901001	CYLINDER	100/80X600	1	65.59
2	90025017	SPINDLE	30/18-179	1	0.63
3	90025018	SLEEVE		1	0.26
4	3301574	LEVER	GN 310-12-125-E-NI M10	1	0.03
5	3300533	SPRING	18/45/7.6/6.88 -1643 SF-TF3	1	0.02
6	3010604	ALLEN SCREW	M12X20 8.8 DIN 912	1	0
7	3090901	CONNECTOR	6010-06-06	4	0.05
8	3110040	USIT-SEAL	R-06 R 3/8"	4	0
100	3133057	HYDRAULIC HOSE	A50005-06-06/241T-06/A50005-06-06/L=670/TEX	1	

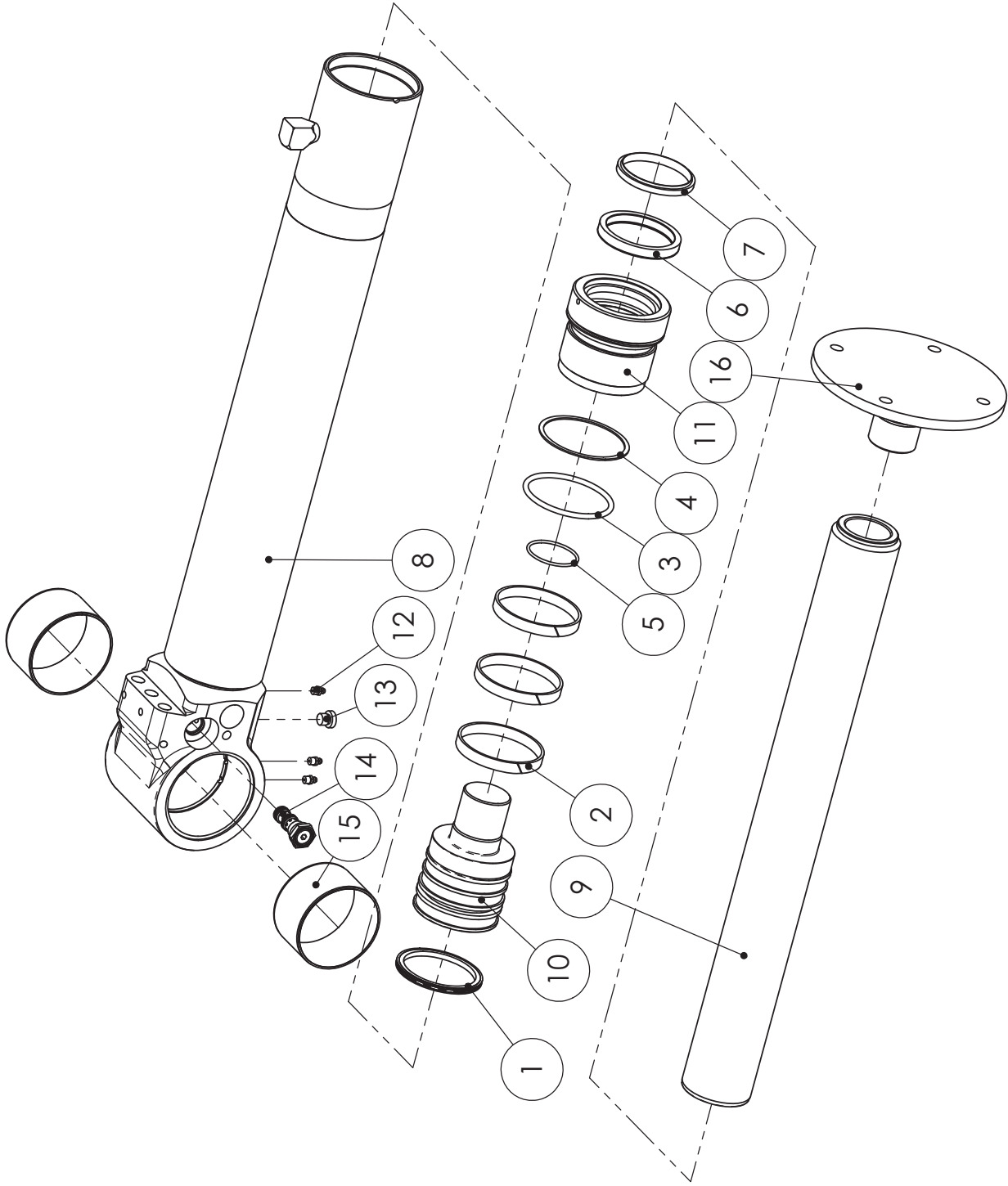

28901001 SYLINTERI

VARAOSAT \ RESERVDELAR \ SPARE PARTS \ ERSATZTEIL



## SPARE PART LIST

Item code	28901001	Revision	-
Title	CYLINDER	Date	13.04.2012
Specification	100/80X600		

Pos	Item code	Title	Specification	Pc	Nto Weight
1	3110821	PISTON SEAL	300 100/84.5X6.3	1	0.1
2	3110072	PISTON GUIDE	E/PWR 100/94X13	3	0.09
3	3111009	O-RING	94.1 X5.7 90 SHORE	1	0.01
4	3111010	SUPPORTING RING	95/105X1.7 PU	1	0
5	3110029	O-RING	54.5X3 90 SHORE	1	0.01
6	3110251	ROD SEAL	NI 300 80/95X12	1	0.16
7	3110111	WIPER SEAL	GA 80/90X7/10	1	0.08
8	28894101	CYLINDER BARREL	100/80X600	1	32.92
9	28894302	PISTON ROD	80	1	16.93
10	28894201	PISTON	100	1	5.26
11	28894202	GUIDANCE	100/80	1	2.67
12	3050003	GREASE NIPPLE	M8X1.25 DIN 71412	3	0
13	3090211	PLUG		1	0.02
14	3120843	VALVE		1	0.13
15	3100344	BUSHING		2	0.38
16	28901106	BASE	WB 802 10060	1	6.27
1-7	3111011	SEAL KIT	TUKIJALKA 100/80	1	

90025721  
100/80x700 RIGHT ( FIXED FOOT )

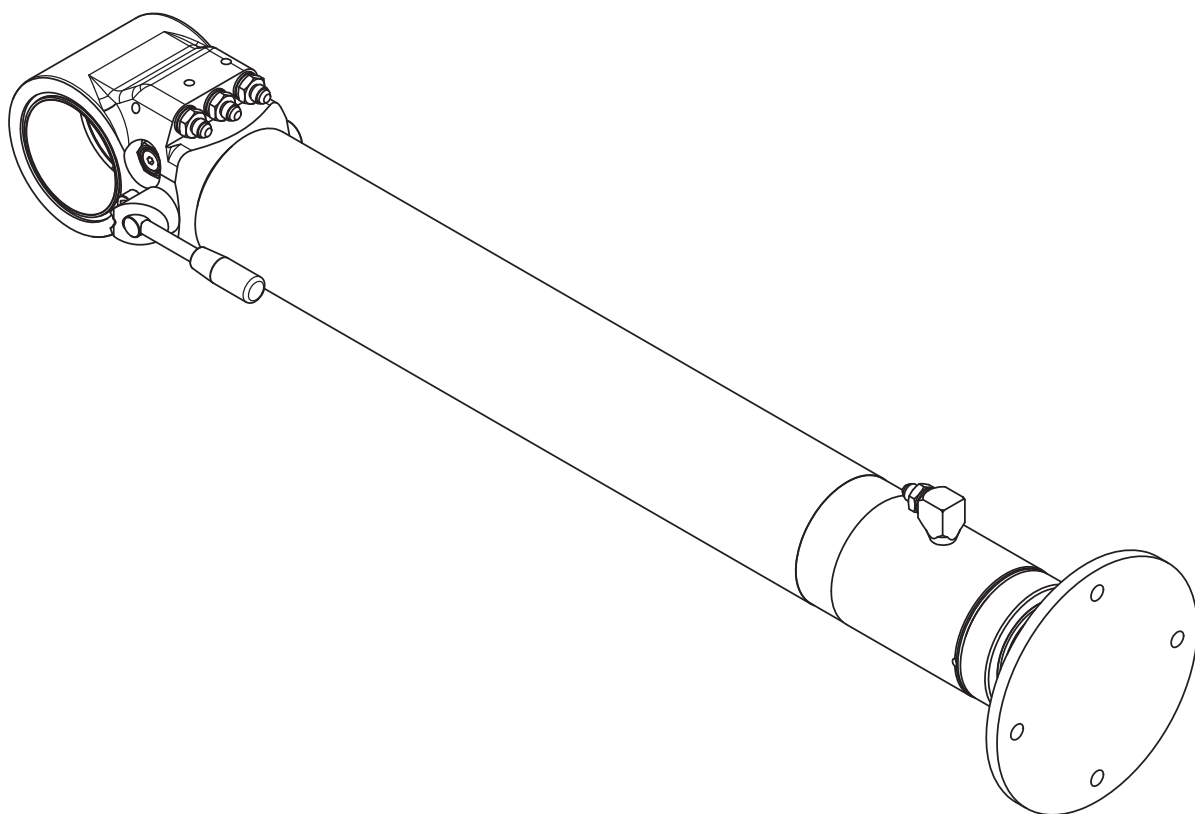
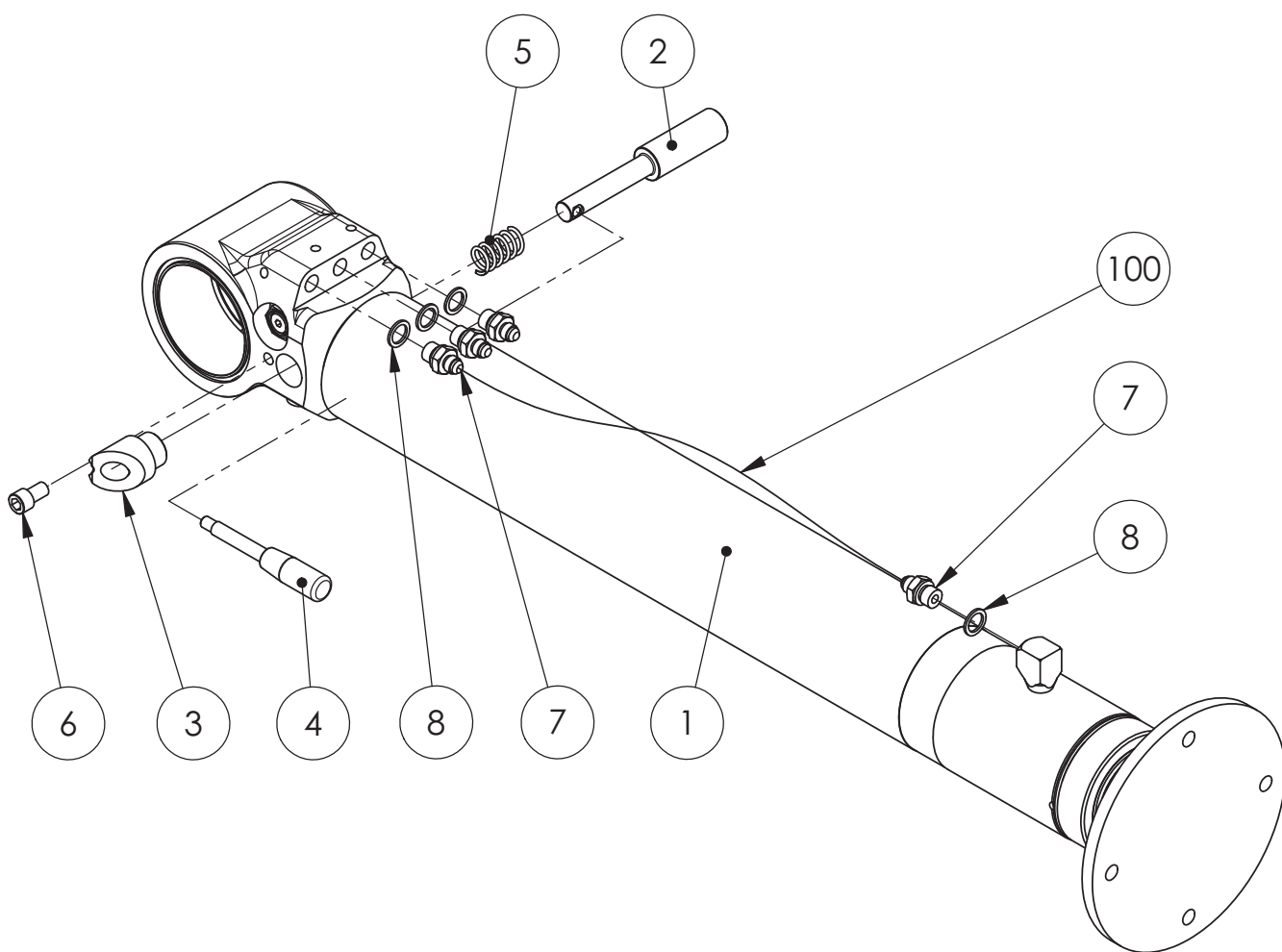

Item code	90025721	Revision	-
Title	STABILIZER	Date	06.09.2012
Specification	100/80X700 RIGHT ( FIXED FOOT )		

Pos	Item code	Title	Specification	Pc	Nto Weight
1	28929001	CYLINDER	100/80X700	1	70
2	90025017	SPINDLE	30/18-179	1	0.63
3	90025018	SLEEVE		1	0.26
4	3301574	LEVER	GN 310-12-125-E-NI M10	1	0.03
5	3300533	SPRING	18/45/7.6/6.88 -1643 SF-TF3	1	0.02
6	3010604	ALLEN SCREW	M12X20 8.8 DIN 912	1	0
7	3090901	CONNECTOR	6010-06-06	4	0.05
8	3110040	USIT-SEAL	R-06 R 3/8"	4	0
100	3133196	HYDRAULIC HOSE	A50005-06-06/241T-06/A50005-06-06/L=770/TEX	1	

90025722

100/80x700 LEFT ( FIXED FOOT )

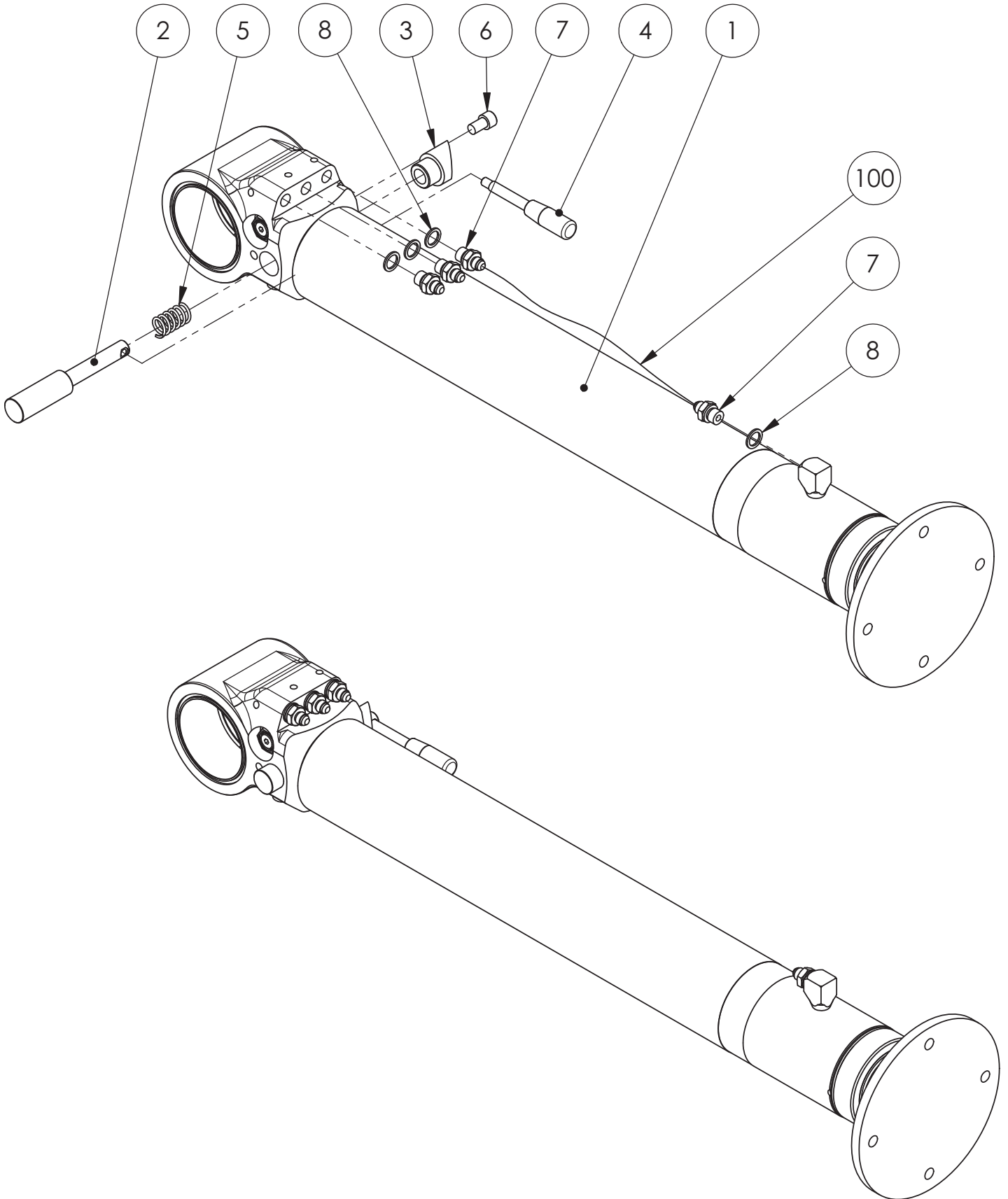



Item code	90025722	Revision	-
Title	STABILIZER	Date	06.09.2012
Specification	100/80X700 LEFT ( FIXED FOOT )		

Pos	Item code	Title	Specification	Pc	Nto Weight
1	28929001	CYLINDER	100/80X700	1	70
2	90025017	SPINDLE	30/18-179	1	0.63
3	90025018	SLEEVE		1	0.26
4	3301574	LEVER	GN 310-12-125-E-NI M10	1	0.03
5	3300533	SPRING	18/45/7.6/6.88 -1643 SF-TF3	1	0.02
6	3010604	ALLEN SCREW	M12X20 8.8 DIN 912	1	0
7	3090901	CONNECTOR	6010-06-06	4	0.05
8	3110040	USIT-SEAL	R-06 R 3/8"	4	0
100	3133196	HYDRAULIC HOSE	A50005-06-06/241T-06/A50005-06-06/L=770/TEX	1	

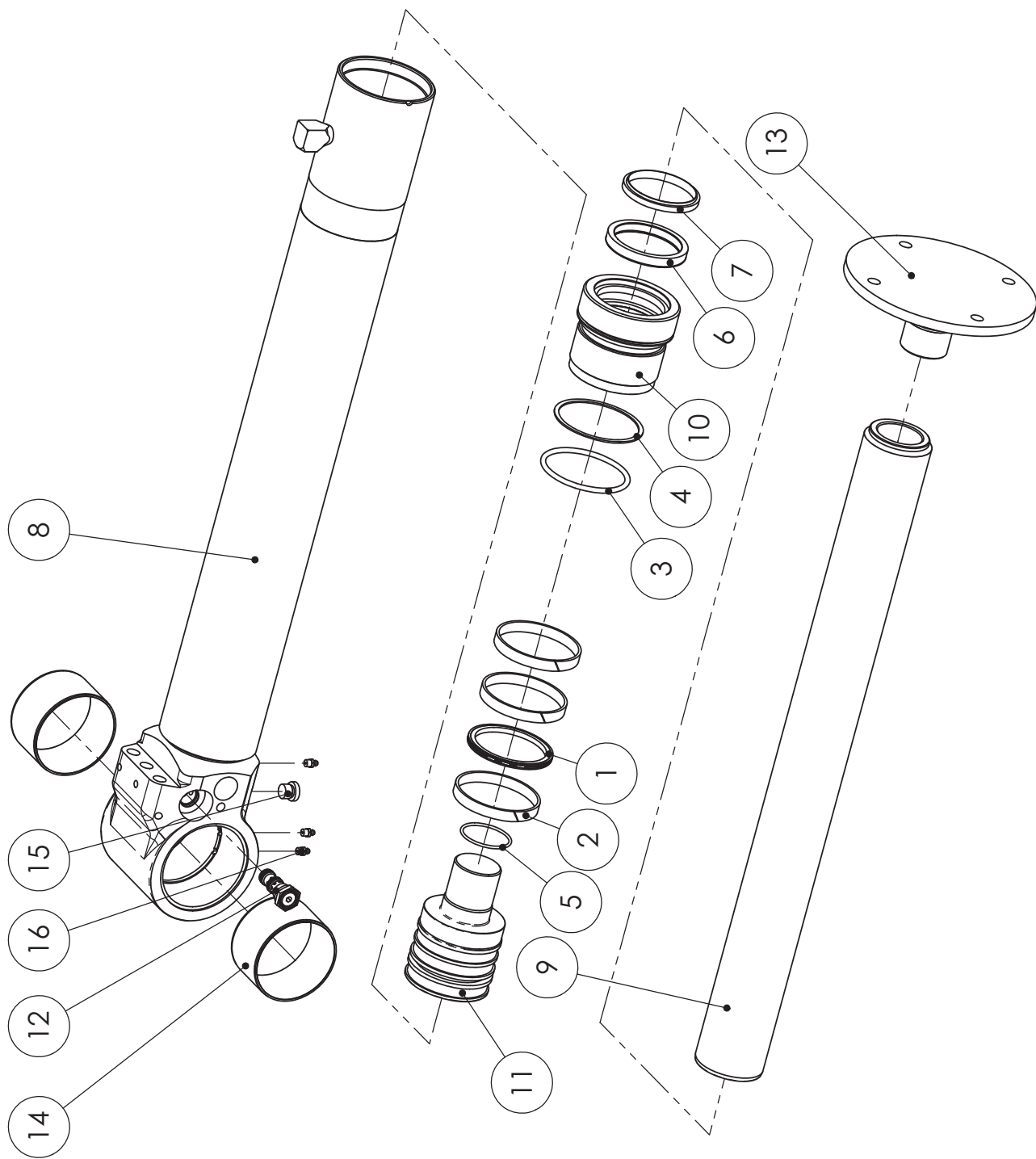

28929001 SYLINTERI

VARAOSAT \ RESERVDELAR \ SPARE PARTS \ ERSATZTEIL



## SPARE PART LIST

Item code	28929001	Revision	-
Title	CYLINDER	Date	05.09.2012
Specification	100/80X700		

Pos	Item code	Title	Specification	Pc	Nto Weight
1	3110821	PISTON SEAL	300 100/84.5X6.3	1	0.1
2	3110072	PISTON GUIDE	E/PWR 100/94X13	3	0.09
3	3111009	O-RING	94.1 X5.7 90 SHORE	1	0.01
4	3111010	SUPPORTING RING	95/105X1.7 PU	1	0
5	3110029	O-RING	54.5X3 90 SHORE	1	0.01
6	3110251	ROD SEAL	NI 300 80/95X12	1	0.16
7	3110111	WIPER SEAL	GA 80/90X7/10	1	0.08
8	28929101	CYLINDER BARREL	100/80X700	1	34.91
9	28929302	PISTON ROD	80/50-820	1	19.34
10	28894202	GUIDANCE	100/80	1	2.67
11	28894201	PISTON	100	1	5.26
12	3120843	VALVE		1	0.13
13	28901106	BASE	TUKIJALKA	1	6.27
14	3100344	BUSHING	WB 802 10060	2	0.38
15	3090210	PLUG		1	0.03
16	3050003	GREASE NIPPLE	M8X1,25 DIN 71412	3	0
1-7	3111011	SEAL KIT	100/80	1	

90025723  
100/80x700 RIGHT ( ADJUSTABLE FOOT )

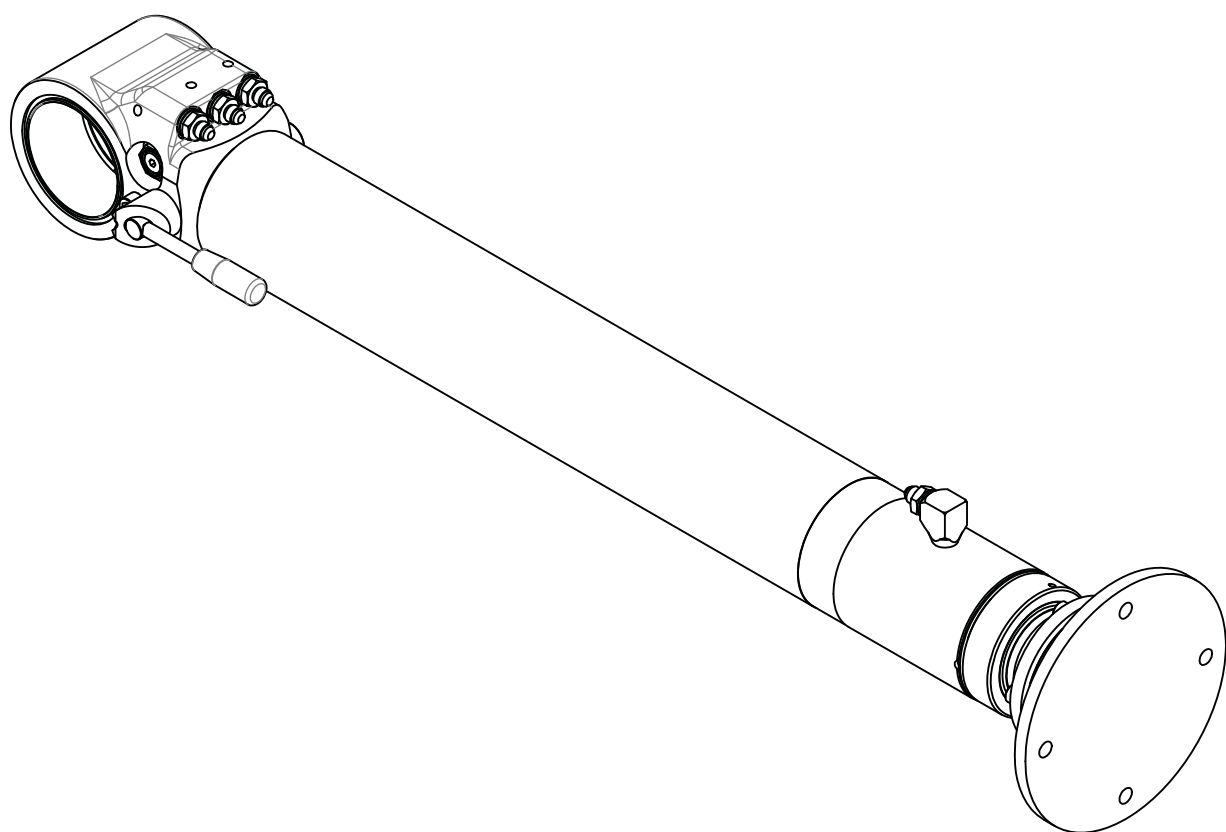
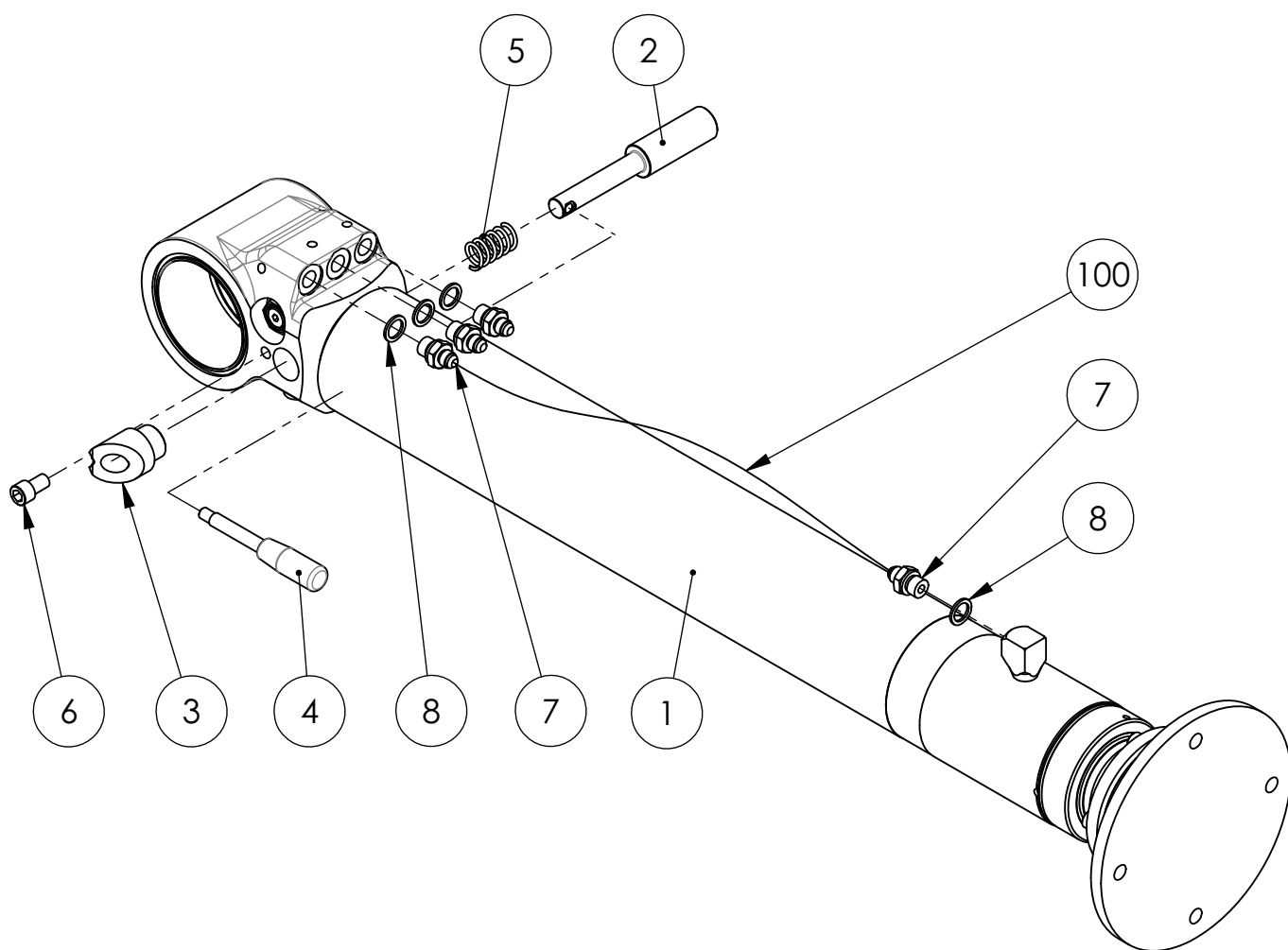

Item code	90025723	Revision	-
Title	STABILIZER	Date	07.09.2012
Specification	90/70X700 RIGHT ( ADJUSTABLE FOOT )		

Pos	Item code	Title	Specification	Pc	Nto Weight
1	28930001	CYLINDER	100/80X700	1	73.59
2	90025017	SPINDLE	30/18-179	1	0.63
3	90025018	SLEEVE		1	0.26
4	3301574	LEVER	GN 310-12-125-E-NI M10	1	0.03
5	3300533	SPRING	18/45/7.6/6.88 -1643 SF-TF3	1	0.02
6	3010604	ALLEN SCREW	M12X20 8.8 DIN 912	1	0
7	3090901	CONNECTOR	6010-06-06	4	0.05
8	3110040	USIT-SEAL	R-06 R 3/8"	4	0
100	3133196	HYDRAULIC HOSE	A50005-06-06/241T-06/A50005-06-06/L=770/TEX	1	

90025724

100/80x700 LEFT ( ADJUSTABLE FOOT )

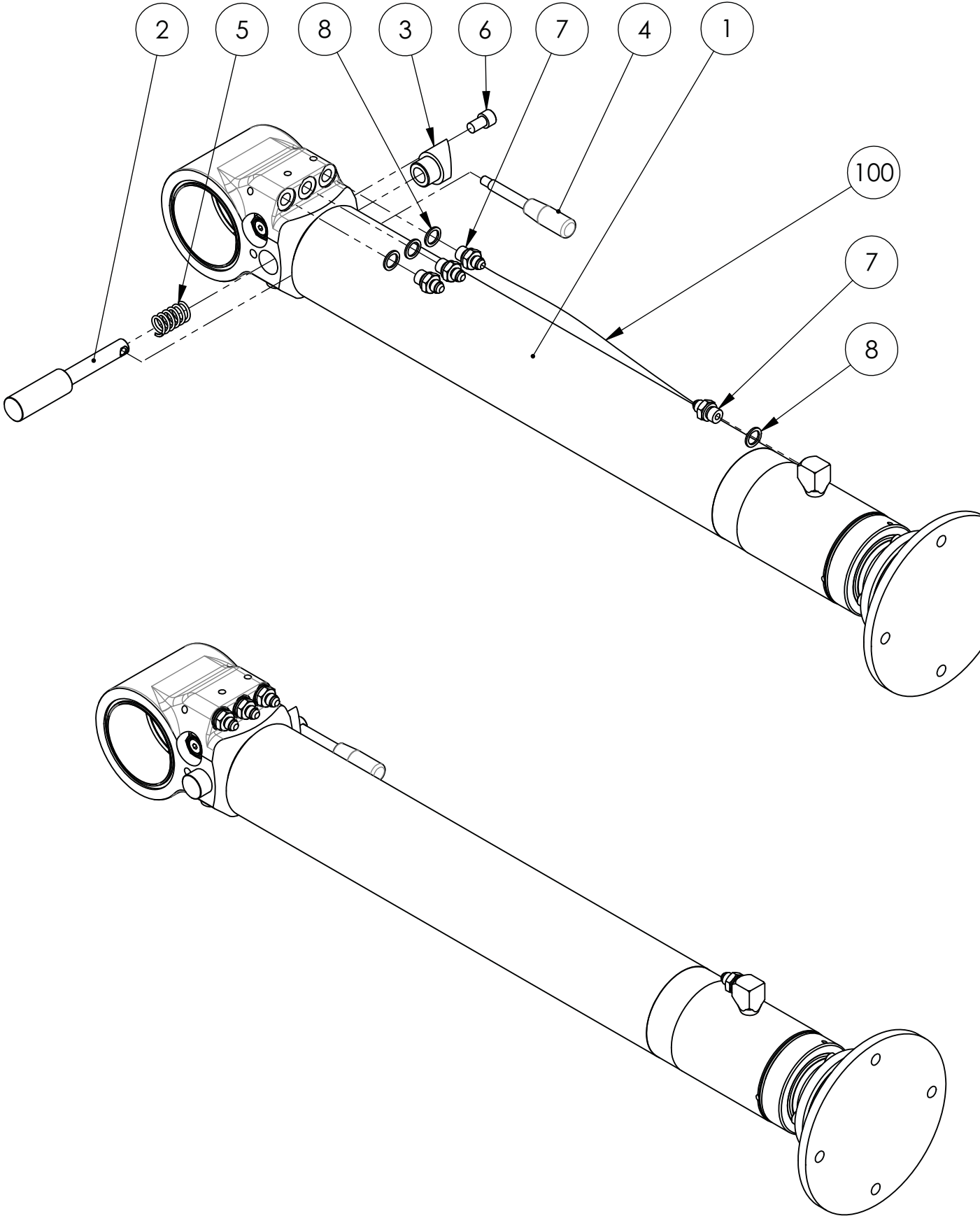

Item code	90025724	Revision	-
Title	STABILIZER	Date	07.09.2012
Specification	100/80X700 LEFT ( ADJUSTABLE FOOT )		

Pos	Item code	Title	Specification	Pc	Nto Weight
1	28930001	CYLINDER	100/80X700	1	73.59
2	90025017	SPINDLE	30/18-179	1	0.63
3	90025018	SLEEVE		1	0.26
4	3301574	LEVER	GN 310-12-125-E-NI M10	1	0.03
5	3300533	SPRING	18/45/7.6/6.88 -1643 SF-TF3	1	0.02
6	3010604	ALLEN SCREW	M12X20 8.8 DIN 912	1	0
7	3090901	CONNECTOR	6010-06-06	4	0.05
8	3110040	USIT-SEAL	R-06 R 3/8"	4	0
100	3133196	HYDRAULIC HOSE	A50005-06-06/241T-06/A50005-06-06/L=770/TEX	1	

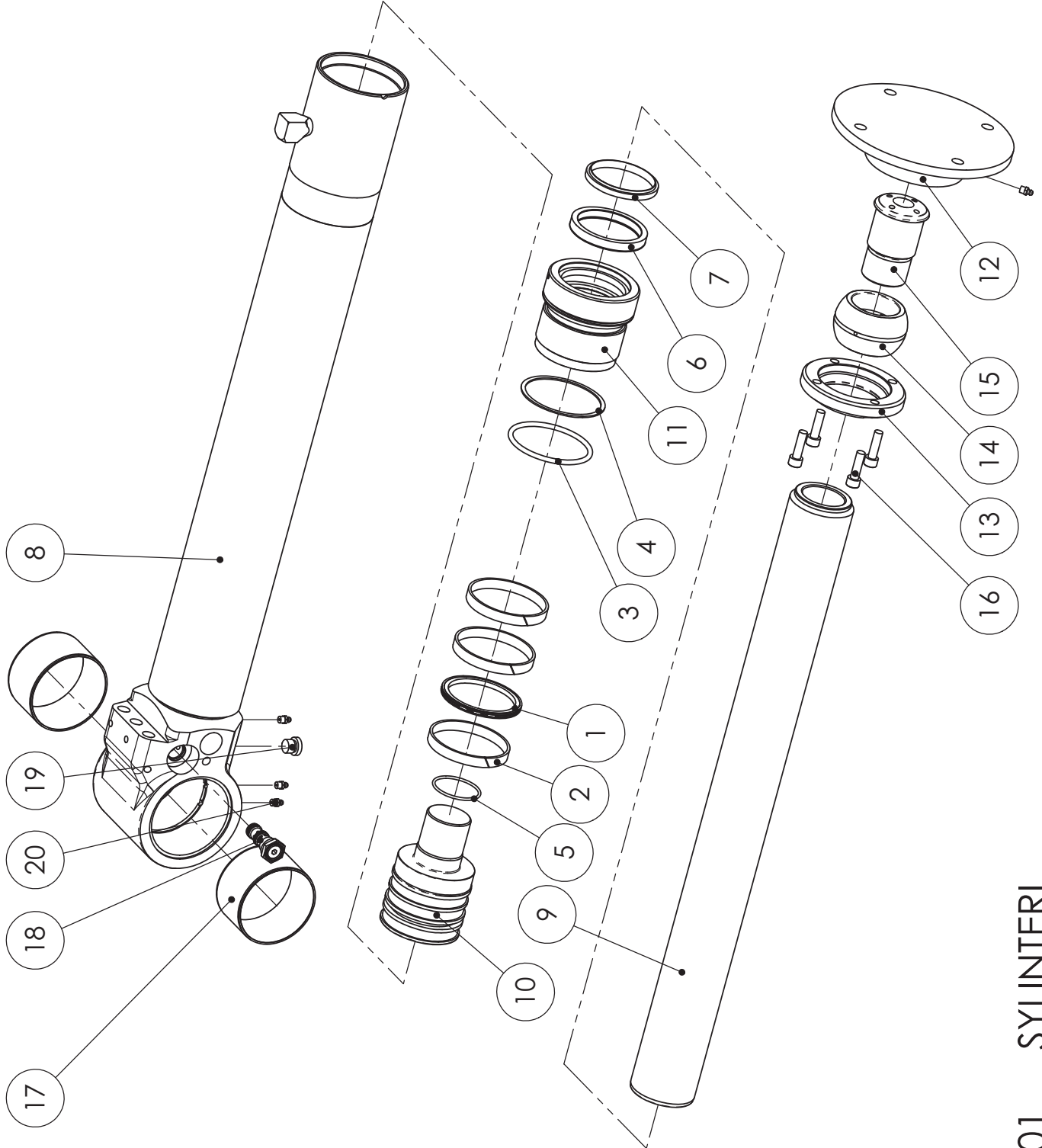

28930001 SYLINTERI

VARAOSAT \ RESERVDELAR \ SPARE PARTS \ ERSATZTEIL





## SPARE PART LIST

Item code	28930001	Revision	-
Title	CYLINDER	Date	05.09.2012
Specification	100/80X700		

Pos	Item code	Title	Specification	Pc	Nto Weight
1	3110821	PISTON SEAL	300 100/84.5X6.3	1	0.1
2	3110072	PISTON GUIDE	E/PWR 100/94X13	3	0.09
3	3111009	O-RING	94.1 X5.7 90 SHORE	1	0.01
4	3111010	SUPPORTING RING	95/105X1.7 PU	1	0
5	3110029	O-RING	54.5X3 90 SHORE	1	0.01
6	3110251	ROD SEAL	NI 300 80/95X12	1	0.16
7	3110111	WIPER SEAL	GA 80/90X7/10	1	0.08
8	28929101	CYLINDER BARREL	100/80X700	1	34.91
9	28929302	PISTON ROD	80/50-820	1	19.34
10	28894201	PISTON	100	1	5.26
11	28894202	GUIDANCE	100/80	1	2.67
12	28861106	BASE		1	5.55
13	28861107	COVER		1	1.07
14	3100428	BEARING	NIVELLAAKERIN PALLO GEF 60 ES	1	1.14
15	28894401	AXLE	60/M55	1	2.1
16	3010970	ALLEN SCREW	M10X35 12.9 DIN 912	4	0
17	3100344	BUSHING	WB 802 10060	2	0.38
18	3120843	VALVE		1	0.13
19	3090210	PLUG		1	0.03
20	3050003	GREASE NIPPLE	M8X1.25 DIN 71412	4	0
1-7	3111011	SEAL KIT	100/80	1	

90025395

L=1200 2114Z, 2117Z, 2024

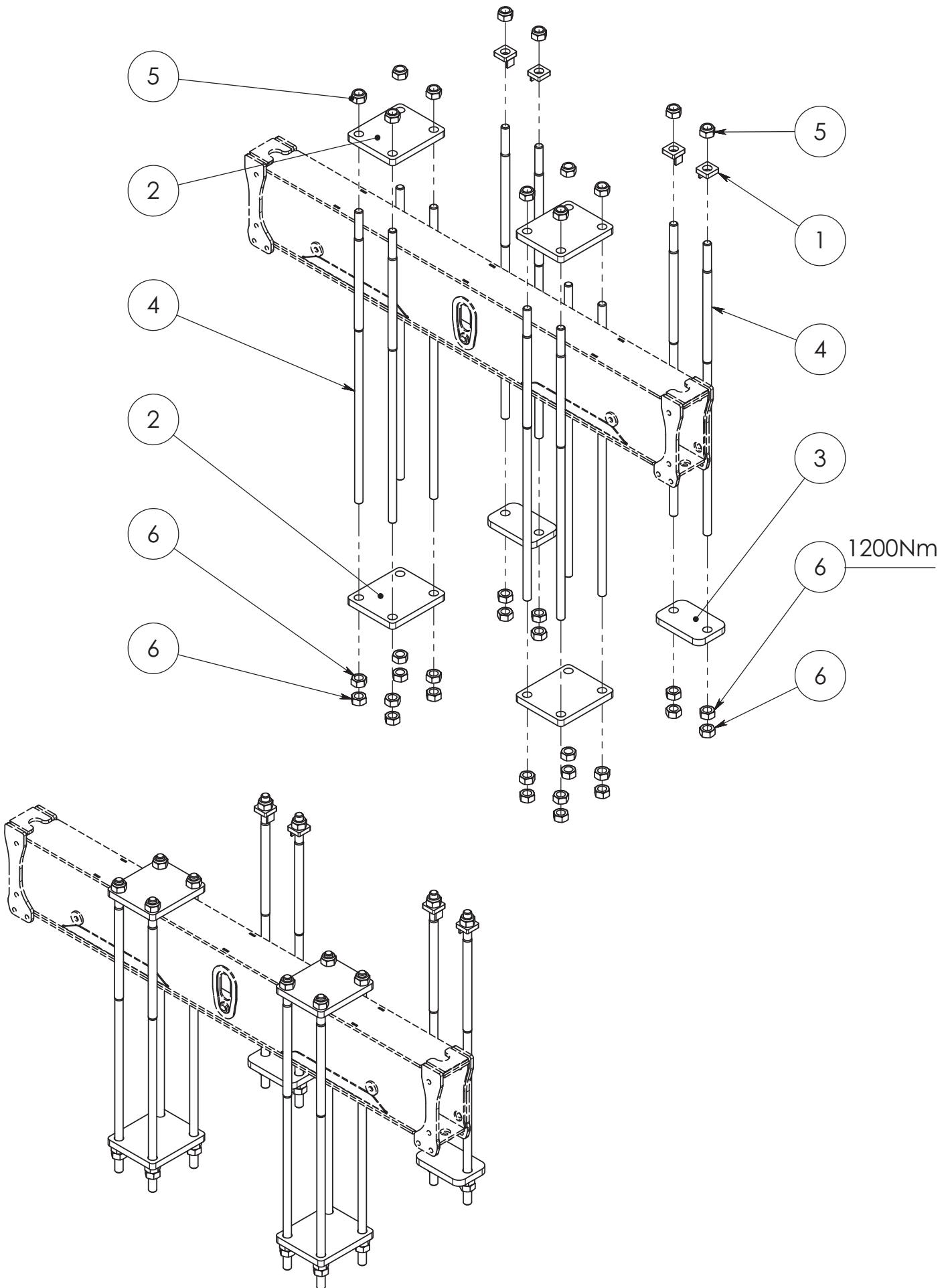

Item code	90025395	Revision	A
Title	FASTENING KIT	Date	01.03.2012
Specification	L=1200 WITH STABILIZER		

Pos	Item code	Title	Specification	Pc	Nto Weight
1	90013054	WASHER	M30-16	4	0.33
2	90021010	FASTENER		4	10.38
3	90022239	FASTENER		2	5.58
4	90024052	SCREW	M30X2-1200	12	6.06
5	3020041	NUT	M30X2 ZN DIN 985	12	0.24
6	3020170	NUT	M30X2 ZN DIN 934	24	0

90024053  
FASTENING KIT L = 1200

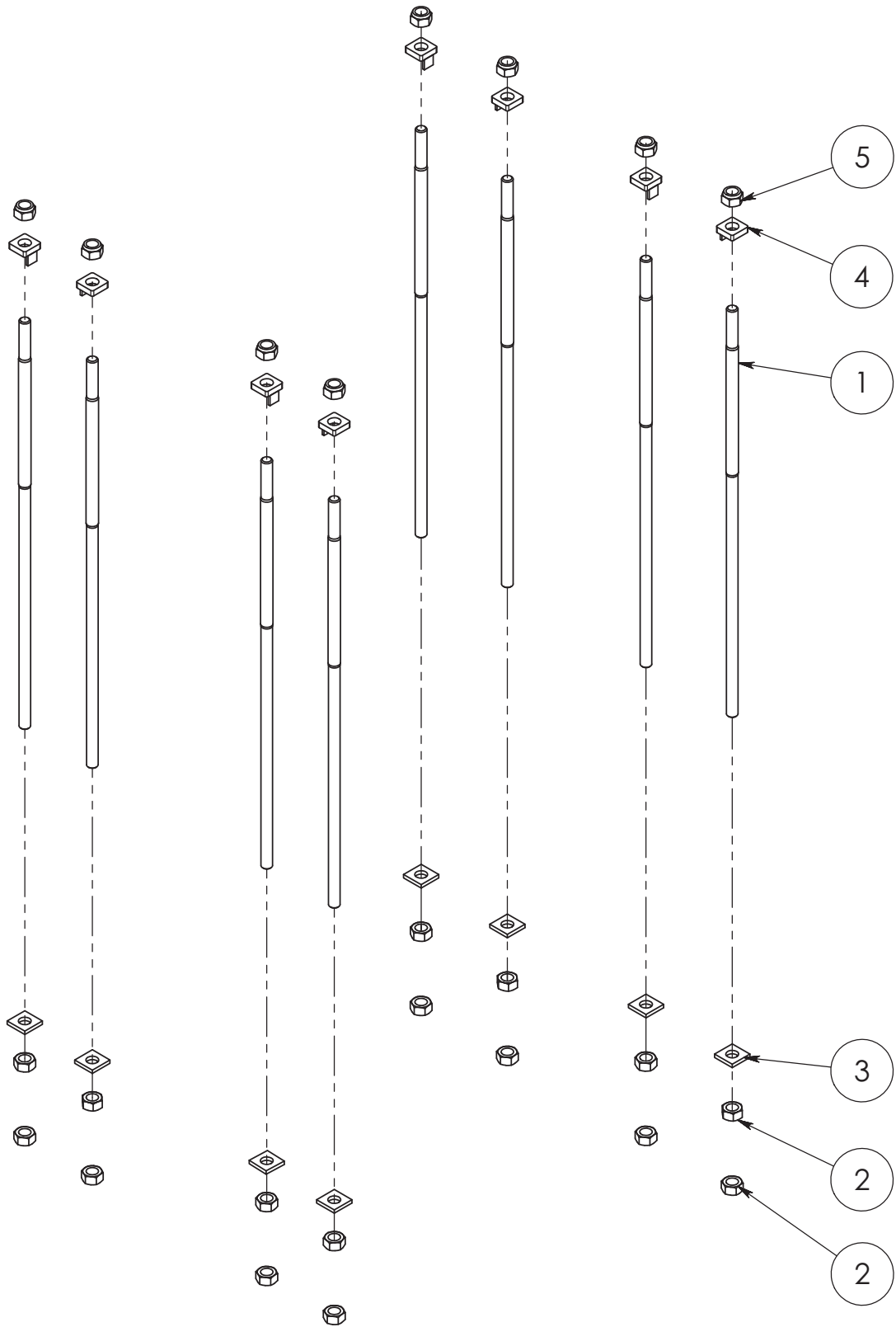

MOMENT 1200Nm (122 kpm)

Item code	90024053	Revision	A
Title	FASTENING KIT	Date	15.11.2010
Specification	L=1200		

Pos	Item code	Title	Specification	Pc	Nto Weight
1	90024052	SCREW	M30X2-1200	8	6.06
2	3020170	NUT	M30X2 ZN DIN 934	16	0
3	90014010	WASHER	60X60/31-10	8	0.22
4	90013054	WASHER	M30-16	8	0.28
5	3020041	NUT	M30X2 ZN DIN 985	8	0.24

90026219

L=750 2114Z, 2117Z, 2024

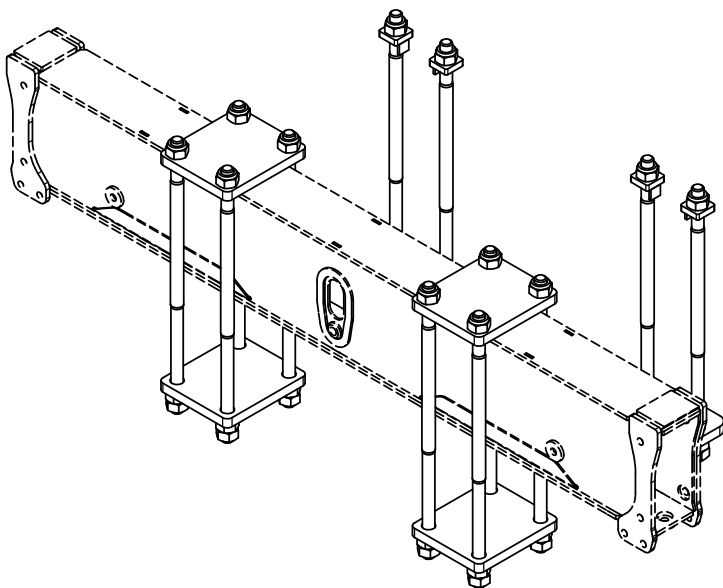
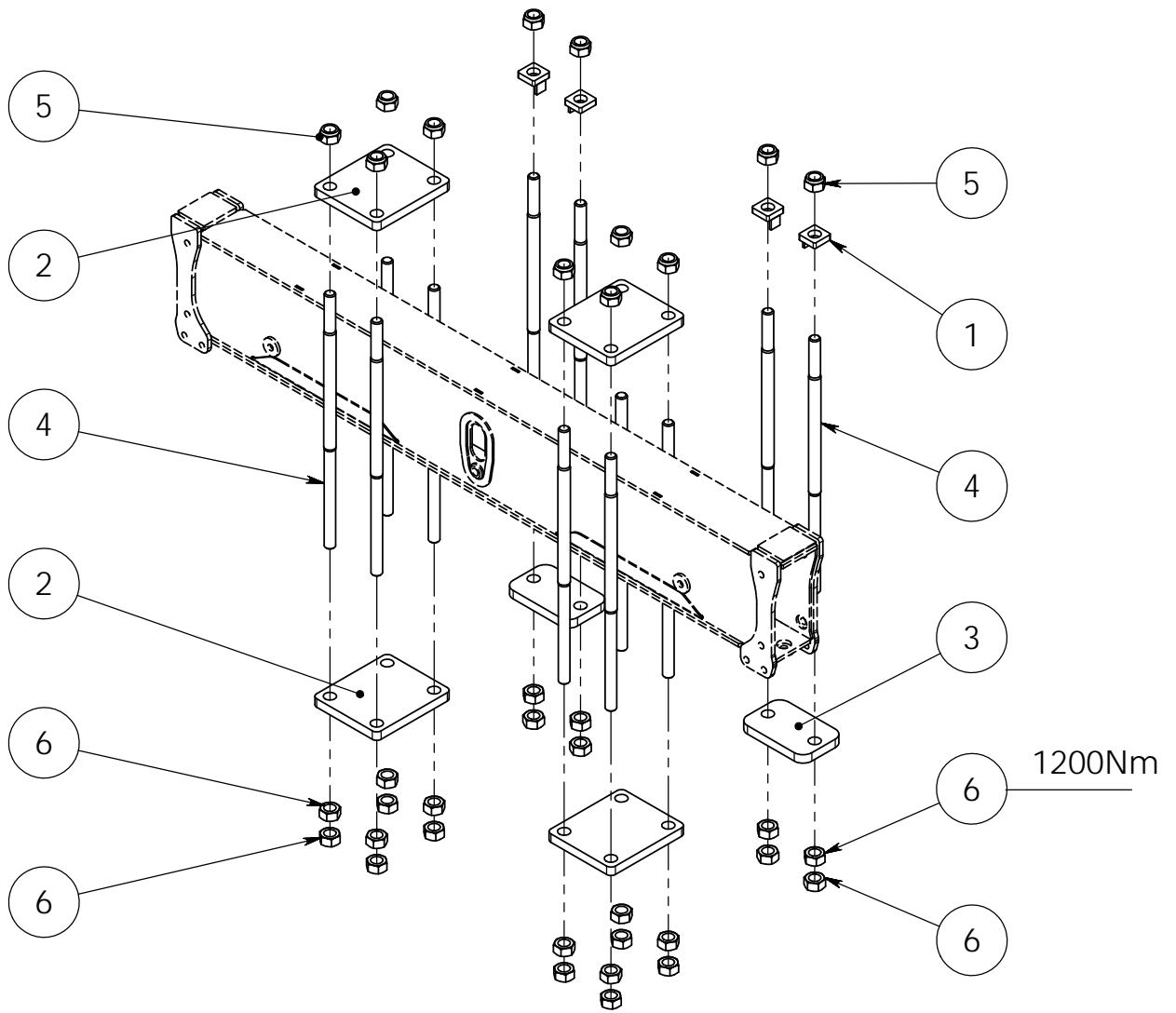

Item code	90026219	Revision	-
Title	FASTENING KIT	Date	27.02.2013
Specification	L=750 2114Z, 2117Z, 2024		

Pos	Item code	Title	Specification	Pc	Nto Weight
1	90013054	WASHER	M30-16	4	0.33
2	90021010	FASTENER		4	10.38
3	90022239	FASTENER		2	5.58
4	90022238	SCREW	M30X2-750	12	3.87
5	3020041	NUT	M30X2 ZN DIN 985	12	0.24
6	3020170	NUT	M30X2 ZN DIN 934	24	0